

# ENERMAX SERIES

**DIESEL GENERATOR**  
**GROUPE ELECTROGENE DIESEL**  
**GRUPO ELECTROGENO DIESEL**  
**GRUPPO ELETTOGENO DIESEL**

MODEL  
 MODÈLE  
 MODELO  
 MODELLO

## IV 141 TSX

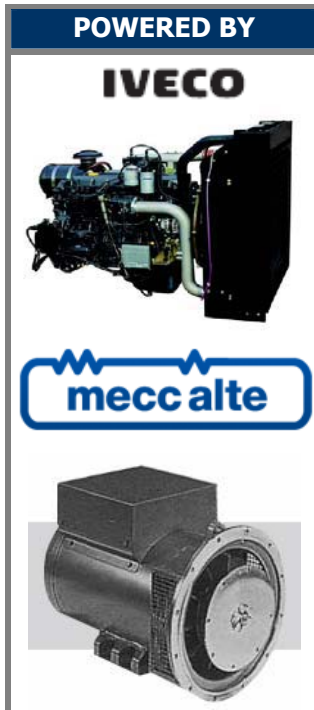

**SUPER SILENT**

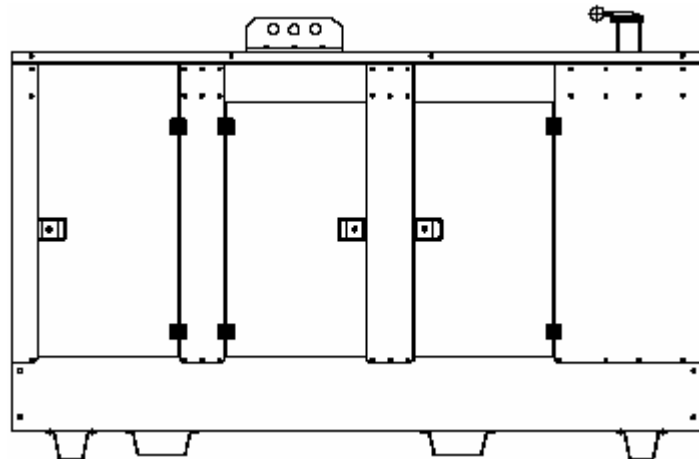

GENERATING SET PERFORMANCE PERFORMANCES DU GROUPE PRESTACIONES DEL GRUPO PRESTAZIONI DEL GRUPPO		50 Hz		60 Hz	
Voltage Voltage Voltaje Tensione		V	400 / 230	V	220 / 127
Continuous Power Puissance service continue Potencia servicio continuo Potenza servizio continuo		PRP	kVA <b>125</b>	kVA	<b>145</b>
Stand-by Power Puissance service secours Potencia servicio emergencia Potenza servizio in emergenza		LTP	kVA <b>140</b>	kVA	<b>160</b>
Continuous Power Puissance service continue Potencia servicio continuo Potenza servizio continuo		PRP	kWe 100	kWe	116
Stand-by Power Puissance service secours Potencia servicio emergencia Potenza servizio in emergenza		LTP	kWe 112	kWe	128
Power factor Facteur de puissance Factor de potencia Fattore di potenza		cos φ	0,8		0,8
Fuel consumption Consommation combustible Consumo de combustible Consumo combustibile		80 %	l/h 19,4	l/h	23,0

ENGINE MOTEUR MOTOR MOTORE	IVECO			NEF67SM1A		
		1500 rpm			1800 rpm	
<b>PERFORMANCE PERFORMANCES PRESTACIONES PRESTAZIONI</b>						
Continuous Power Puissance service continue Potencia servicio continuo Potenza servizio continuo	PRP	kWm	110	kWm	126	
Stand-by Power Puissance service secours Potencia servicio emergencia Potenza servizio in emergenza	LTP	kWm	121	kWm	138	
Specific fuel consumption Consumption spécifique combustible Consumo específico de combustible Consumo specifico combustibile		g/kWh	50 % 216 80 % 214 100 % 213	g/kWh	50 % 232 80 % 219 100 % 216	
Diesel 4 Stroke – Injection type Diesel 4 temps – Type injection Diesel 4 tiempos – Tipo de inyeccion Diesel a 4 tempi – Tipo di iniezione						Direct Directe Directa Diretta
Aspiration type Type d’aspiration Tipo de aspiracion Tipo d’aspirazione						Turbocharged Suraalimentée sobrealimentato sovralimentata
Cooling system Refroidissement Sistema de refrigeracion Raffreddamento						Water Eau Agua Acqua
Speed governor Régulateur de tours Regulador Regolatore di giri						Mechanical Mécanique Mecanico Meccanico
Cylinders, numbers and arrangement Nombre et disposition des cylindres Cilindros, numero y disposicion Numero e disposizione dei cilindri						6 L
Total displacement Cylindrée totale Cilindrata total Cilindrata totale				cm <sup>3</sup>	6700	
Bore x stroke Alésage x course Diámetro x carrera Alesaggio x corsa				mm	104 x 132	
Engine electric system voltage Voltage système électrique moteur Voltaje sistema eléctrico motor Voltaggio sistema elettrico motore					12 V	
Derating for temperature Déclassement pour temperature Declasamiento para temperatura Declasseamento per temperatura				0 ÷ 40°C	0	
				> 40 °C	1% / 5 °C	
Derating for altitude Déclassement pour altitude Declasamiento para altitud Declasseamento per altitudine				0 ÷ 1000 m	0	
				1000 ÷ 3000 m	2 % / 500 m	
				> 3000 m	4 % / 500 m	
Derating for relative humidity Déclassement pour humidité relative Declasamiento para humedad relativa Declasseamento per umidità relativa				30°C & 50% RH	0	
				30°C & >RH 50%	0,45 %/ 10% RH	

ALTERNATOR ALTERNATEUR ALTERNADOR ALTERNATORE		MECCALTE				
PERFORMANCE PERFORMANCES PRESTACIONES PRESTAZIONI		1500 rpm		1800 rpm		
Model Modèle Modelo Modello		ECP34-1L/4		ECP34-1L/4		
Continuous Power Puissance service continue Potencia servicio continuo Potenza servizio continuo		40 °C	kVA kWe	<b>130,0</b> 104,0	KVA kWe	<b>145,0</b> 116,0
Stand-by Power Puissance service secours Potencia servicio emergencia Potenza servizio in emergenza		40 °C	KVA kWe	<b>137,0</b> 109,6	KVA kWe	<b>165,0</b> 132,0
Stand-by Power Puissance service secours Potencia servicio emergencia Potenza servizio in emergenza		27 °C	KVA kWe	<b>142,0</b> 113,6	KVA kWe	<b>170,0</b> 136,0
Efficiency Rendement Eficienza Efficienza			2/4 3/4 4/4	91,5 % 93,2 % 92,7 %	2/4 3/4 4/4	93,3 % 94,9 % 94,4 %
Standard winding connections Liaison des bobinages Tipo de conexión Collegamento avvolgimenti			Y		YY	
Exciter Eccitatrice Excitador Eccitatrice		<b>brushless</b> rotating exciter design with solid state pivotante <b>sans brosses</b> avec pont de diodes pivotants puente de diodos <b>sin escobillas</b> rotantes rotante <b>senza spazzole</b> con ponte di diodi rotanti				
Poles Poles Polos Poli		4				
Phases Phases Fases Fasi		3 + N				
Wires Fils Hilos Morsetti		12				
Voltage accuracy Regulation Voltage Regulación voltaje Regolazione tensione		± 1 %				
Insulation class Classe d' isolation Classe de aislamiento Classe di isolamento		H				
Enclosure Degré de protection mécanique Grado de protección mecánica Grado di protezione meccanica		IP 21				
Air volume Volume d'air Volumen de aire Volume d'aria		50 Hz	19,3 m <sup>3</sup> /min			
		60 Hz	23,0 m <sup>3</sup> /min			
Standard AVR model Modèle AVR standard Modelo AVR standard Modello AVR standard		<b>SR7/2</b>				
Derating for temperature Déclassement pour température Declasamiento para temperatura Declassamento per temperatura		0 ÷ 40°C	0			
		> 40 °C	3 % / 5°C			
Derating for altitude Déclassement pour altitude Declasamiento para altitud Declassamento per altitudine		0 ÷ 1500 m	0			
		1500 ÷ 2500 m	3% / 500 m			
		2500 ÷ 3000 m	4% / 500 m			

**LOGISTIC INFORMATION**  
**INFORMATIONS LOGISTIQUES**  
**INFORMATION LOGISTICA**  
**INFORMAZIONI LOGISTICHE**

	Integrated fuel tank capacity Capacité réservoir intégré Capacidad Tanque integrado Capacità Serbatoio integrato			Weight Poids Peso Peso	Dimensions Cotes d'encombrement Medidas externas Dimensioni d'ingombro		
	(L)			(kg)	(cm)		
	STD	EXTRA1	EXTRA1		L	W	H
SOUND PROOF VERSION VERSION INSONORISEE VERSION INSONORISADA VERSIONE INSONORIZZATA	185	270	ON REQUEST	1760	295	110	203

**GENSET STANDARD EQUIPMENT**  
**EQUIPEMENT STANDARD GROUPE ELECTROGENE**  
**EQUIPAMIENTO STANDARD GRUPO ELECTROGENO**  
**EQUIPAGGIAMENTO STANDARD GRUPPO ELETTOGENO**

GB	F	E	I
<ul style="list-style-type: none"> <li>• Heavy duty steel base frame</li> <li>• Vibration dampers</li> <li>• Integrated fuel tank</li> <li>• Silencer industrial type</li> <li>• Battery</li> <li>• Manual control panel model <b>MCP 120-22</b></li> <li>• Key start switch</li> <li>• Emergency stop button</li> <li>• Sound proof canopy of galvanized steel with <b>residential</b> silencer for <b>Super Silent</b> version</li> </ul>	<ul style="list-style-type: none"> <li>• Châssis acier</li> <li>• Amortisseurs de vibrations</li> <li>• Réservoir intégré</li> <li>• Silencieux industriel</li> <li>• Batterie</li> <li>• Coffret de contrôle manuel <b>MCP 120-22</b></li> <li>• Clé de démarrage</li> <li>• Bouton arrêt d'urgence</li> <li>• Capote d'insonorisation d'acier galvanisé avec silencieux <b>résidentiel</b> pour la version <b>Super Silent</b></li> </ul>	<ul style="list-style-type: none"> <li>• Telar de acero</li> <li>• Apagadores de vibracion</li> <li>• Tanque combustible</li> <li>• Silenciador industrial</li> <li>• Bateria</li> <li>• Cuadro electrico manual <b>MCP 120-22</b></li> <li>• Llave par arranque</li> <li>• Botón parada de emergencia</li> <li>• Cabina de insonorización de acero cincado con silenciador <b>residencial</b> por la versión <b>Super Silent</b></li> </ul>	<ul style="list-style-type: none"> <li>• Basamento in acciaio</li> <li>• Antivibranti</li> <li>• Serbatoio integrato</li> <li>• Silenziatore industriale</li> <li>• Batteria avviamento</li> <li>• Chiave avviamento</li> <li>• Quadro elettrico manuale <b>MCP 120-22</b></li> <li>• Pulsante arresto di emergenza</li> <li>• Cabina di insonorizzazione di acciaio zincato con marmitta <b>residenziale</b> per la versione <b>Super Silent</b></li> </ul>

**MANUAL CONTROL PANEL**  
**COFFRET ELECTRIQUE MANUEL**  
**CUADRO ELECTRICO MANUAL**  
**QUADRO ELETTRICO MANUALE**



## MCP 120 – 22

**200 A** (400 V - 3 ph - 50Hz - 1500 rpm)  
**400 A** (220 V - 3 ph - 60Hz - 1800 rpm)

<b>STANDARD EQUIPMENT:</b> 4 poles circuit breaker Electronic control board <b>SPG 120</b> Key start switch Control panel box key Emergency Stop button	<b>EQUIPEMENT STANDARD:</b> Disjoncteur de protection 4 pôles Fiche électronique <b>SPG 120</b> Interrupteur de démarrage à clé Clé pour serrure du coffret Interrupteur d'arrêt d'urgence	<b>EQUIPAMIENTO STANDARD:</b> Interruptor magnetotermico 4 polos Carta electronica <b>SPG 120</b> Llave de arranque Llave cuadro Botón de parada de emergencia	<b>EQUIPAGGIAMENTO STANDARD:</b> Interruttore magnetotermico 4 poli Scheda elettronica <b>SPG 120</b> Interruttore di avviamento a chiave Chiave quadro Pulsante di arresto di emergenza
--	---	---	---

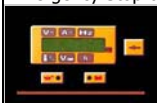

## SPG 120

**CONTROL BOARD**  
**CARTE ELECTRONIQUE DE CONTROL**  
**CARTA ELECTRONICA DE CONTROL**  
**SCHEDA ELETTRONICA DI CONTROLLO**

PROTECTIONS	PROTECTIONS	PROTECCIONES	PROTEZIONI
Low oil pressure Low fuel level Overload Over/Under frequency Low voltage Over/Under battery voltage Belt breakage	Basse pression huile Bas niveau carburant Surcharge Sur/sous fréquence Bas voltage Sur/sous voltage batterie Rupture de la courroie	Baja presión de aceite Bajo nivel combustible Sobrecarga Sobre/bajo frecuencia Bajo voltaje Sobre/bajo voltaje batería Ruptura correa	Bassa pressione olio Basso livello carburante Sovraccarico Sovra/sotto frequenza Basso voltaggio Sovra/sotto voltaggio batterie Rottura cinghia
DIGITAL METERS	VOYANT NUMERIQUE POUR	VISOR DIGITAL PARA	MISURATORE DIGITALE PER
Voltmeter Ammeter (3 phases) Frequency meter Hour-meter Battery voltage meter Fuel level	Volts Ampères (3 phases) Fréquence Heures Voltage batterie Niveau carburant	Voltios Amperios (3 fases) Frecuencia Horas Voltaje batería Nivel carburante	Volt Ampere (3 fasi) Frequenza Ore Voltaggio batterie Livello carburante
INDICATORS	INDICATEURS	INDICADORES	INDICATORI
Indicator for periodic maintenance Light indicator for oil and battery Light indicator for protection ON	Indicateur pour entretien périodique Indicateur lumineux huile et batterie Indicateur lumineux de protection	Indicador de manutención periódica Indicador luminoso aceite y batería Indicador luminoso protección	Indicatore di manutenzione periodica Indicatore luminoso per olio e batteria Indicatore luminoso di protezione

**AUTOMATIC CONTROL PANEL  
COFFRET ELECTRIQUE AUTOMATIQUE  
CUADRO ELECTRICO AUTOMATICO  
QUADRO ELETTRICO AUTOMATICO**

<p>1) <b>ACP 7320 ATS</b></p> 	<p><b>COMPLETE CONTROL PANEL FREE STANDING TYPE</b> Equipment: control board, circuit breaker, battery charger, transfer switch, box key. <b>COFFRET ELECTRIQUE COMPLET TYPE ARMOIRE SEPRE DU GROUPE</b> Equipement : carte électronique de contrôle, disjoncteur de protection, chargeur de batterie, inverseur de source, clé coffret. <b>CUADRO ELECTRICO COMPLETO EN ARMARIO SEPARADO DEL GRUPO</b> Equipamiento: carta electronica de controllo, interruptor magnetotermico, cargador de bateria, transferencial, llave quadro. <b>QUADRO ELETTRICO COMPLETO SEPARATO DAL GRUPPO</b> Equipaggiamento: scheda elettronica di controllo, interruttore magnetotermico, carica batteria, telecommutazione e chiave quadro.</p>
<p>2) <b>ACP 7320 AMF</b></p> 	<p><b>AMF CONTROL PANEL FITTED ON THE GEN-SET WITHOUT TRANSFER SWITCH</b> Equipment: control board, circuit breaker, battery charger, box key. <b>COFFRET ELECTRIQUE MONTE SUR LE GROUPE SANS INVERSEUR DE SOURCE</b> Equipement : carte électronique de contrôle, disjoncteur de protection, chargeur de batterie, clé coffret. <b>CUADRO ELECTRICO MONTADO SOBRE EL GRUPO SIN TRANSFERENCIAL</b> Equipamiento: carta electronica de controllo, interruptor magnetotermico, cargador de bateria, llave quadro. <b>QUADRO ELETTRICO MONTATO SUL GRUPPO ELETTROGENO SENZA TELECOMMUTAZIONE</b> Equipaggiamento: scheda elettronica di controllo, interruttore magnetotermico, carica batteria, chiave quadro.</p>
<p>3) <b>ACP 7320 STS</b></p>  	<p><b>CONTROL PANEL FITTED ON THE GEN-SET WITH TRANSFER SWITCH SUPPLIED IN A SEPARATED BOX</b> Equipment: control board, circuit breaker, battery charger, box key, separate transfer switch. <b>COFFRET ELECTRIQUE MONTE SUR LE GROUPE + INVERSEUR DE SOURCE FOURNI DANS UN COFFRET SEPRE</b> Equipement : carte électronique de contrôle, disjoncteur de protection, chargeur de batterie, inverseur de source séparé, clé coffret. <b>CUADRO ELECTRICO MONTADO SOBRE EL GRUPO CON TRANSFERENCIAL SEPARADO</b> Equipamiento: carta electronica de controllo, interruptor magnetotermico, cargador de bateria, llave quadro, transferencial separado. <b>QUADRO ELETTRICO MONTATO SUL GRUPPO ELETTROGENO CON TELECOMMUTAZIONE SEPARATA</b> Equipaggiamento: scheda elettronica di controllo, interruttore magnetotermico, carica batteria, chiave quadro, telecommutazione in armadio separato.</p>

**CONTROL BOARD  
CARTE ELECTRONIQUE DE CONTROL  
CARTA ELECTRONICA DE CONTROL  
SCHEDA ELETTRONICA DI CONTROLLO**

GB	F	E	I
<p>The DSE7320 is an Automatic Mains Failure Control Module designed to automatically start and stop diesel generating sets that include electronic and non electronic engines. The module also provides excellent genset monitoring and protection features.</p>	<p>La DSE7320 est une carte de contrôle projetée pour démarrer et arrêter automatiquement groupes électrogènes diesels avec moteurs électroniques et non électroniques. La carte représente un système excellent de contrôle et de protection du groupe électrogène.</p>	<p>La DSE7320 es una carta de control para arrancar y parar automáticamente grupos electrógenos diesel con motores electrónicos y no electrónicos. La carta constituye un excelente sistema de control y protección del grupo electrógeno.</p>	<p>La DSE7320 è una scheda di controllo progettata per avviare e arrestare automaticamente gruppi elettrogeni diesel con motori elettronici e non elettronici. La scheda costituisce un eccellente sistema di controllo e di protezione del gruppo elettrogeno.</p>
FEATURES	EQUIPEMENT	EQUIPMENT	EQUIPAGGIAMENTO
<p>Stop/reste – Auto – Manual – Start LCD display scroll Event log view Acoustic alarm</p>	<p>Fiche électronique de contrôle DSE7320 Disjoncteur de protection Chargeur de batterie Bouton poussoir arrête d'urgence</p>	<p>Ficha electrónica de control DSE7320 Interruptor magnetotermico Cargador de batería Boton de parada de emergencia</p>	<p>Scheda elettronica di controllo DSE7320 Interruttore magnetotermico Carica batteria Pulsante stop emergenza</p>
DIGITAL MEASURING	MESURES NUMERIQUES	MEDIDAS DIGITALES	MISURAZIONI DIGITALI
<p>Generator volts (3 phases) Generator amperes (3 phases) Generator frequency KW-meter kVA-meter Cos φ- meter Rpm meter Water temperature (optional) Oil pressure (optional) Gen set hours counter Mains volts Battery volts Mains frequency Charging voltage Start-counter Fuel level %</p>	<p>Voltmètre générateur (3 phases) Ampèremètre générateur (3 phases) Fréquencemètre générateur KW- mètre kVA- mètre Cos φ- mètre Tm mètre Température eau (facultatif) Pression huile (facultatif) Totalisateur d'heures de marche Voltmètre secteur Voltmètre batterie Fréquence réseau Tension de charge Compteur démarrages Niveau combustible %</p>	<p>Voltmetro (3 fases) Amperimetro (3 fases) Frecuencimetro KW- metro kVA- metro Cos φ- metro Revoluciones por minuto metro Termometro agua (opcional) Presión aceite (opcional) Medida horas de marcha Voltmetro tensión de red Voltmetro batería Frecuencia red Tensión de carga Numero de arranques Nivel carburante %</p>	<p>Voltmetro tensione generatore (3 fasi) Amperometro generatore (3 fasi ) Frequenzimetro generatore KW- metro kVA- metro Cos φ- metro Gm metro Temperatura acqua (facoltativo) Pressione olio (facoltativo) Contaore di funzionamento gruppo Voltmetro tensione rete Voltmetro batteria Frequenza rete Tensione di carica Contavviamenti Livello carburante %</p>
INDICATORS	INDICATEURS	INDICADORES	INDICATORI
<p>Mains live Generator live Mains contactor closed Generator contactor closed Engine running</p>	<p>Présence secteur Présence tension générateur Inverseur secteur fermé Inverseur générateur fermé Moteur en marche</p>	<p>Baja presión de red Presencia tensión grupo Transferencial red cerrado Transferencial grupo cerrado Motor en marcha</p>	<p>Presenza tensione di rete Presenza tensione generatore Erogazione da rete Erogazione da gruppo Motore avviato</p>
PROTECTIONS	PROTECTIONS	PROTECCIONES	PROTEZIONI
<p>Low oil pressure High engine temperature Low fuel level Fail to start Fail to stop Emergency stop Over/under frequency Over/under voltage Over/under speed Fuel level Belt breakage Over current Over/under battery voltage</p>	<p>Bas pression huile moteur Haute température moteur Bas niveau combustible Non démarrage Non arrêt Arrêt d'urgence Sur/sous fréquence Sur/sous voltage Sur/sous vitesse Niveau de combustible Rupture courroie Surcourant Sur/sus la tension de batterie</p>	<p>Baja presión aceite Elevada temperatura motor Baja nivel carburante Falta de arranque Falta de parada Parada de emergencia Sobre/bajo frecuencia Sobre/bajo voltaje Sobre/bajo velocidad nivel de combustible Ruptura correa Corriente maxima Sobre/bajo voltaje de la batería</p>	<p>Bassa pressione olio Alta temperatura motore Basso livello di carburante Mancato avviamento Mancato arresto Stop d'emergenza Sovra/sotto frequenza Sovra/sotto voltaggio Sovra/sotto velocità Livello del carburante Rottura cinghia Sovraccorrente Sovra/sotto tensione della batteria</p>

<b>SOUNDPROOF CANOPY</b> <b>CAPOTE D'INSONORISATION</b> <b>CAPOTA DE INSONORIZACION</b> <b>CABINA INSONORIZATA</b>			
<b>GB</b>	<b>F</b>	<b>E</b>	<b>I</b>
<p>The TecnoGen Super Silent soundproof canopy has been designed with the aim of achieving the maximum noise level reduction and to provide a perfect cooling of the engine. The cooling airflow is forced through fixed circuits. The canopy is suitable for tropical ambient application. The exhaust gas silencer is residential type internally mounted. The canopy is completely built of hot galvanized carbon sheet steel. The sheets have a thickness 20/10. The structure is fully bolted, fixed by a special polyethylene sealing, completely free from electrical installation. All the panels can be easily removed. The cab is provided with doors of wide opening for easy access to generating set for the maintenance operations. The soundproofing materials are highly fire resistant and self-extinguishing.</p>	<p>La capote insonorisée TecnoGen Super Silent a été conçue pour atteindre le niveau de bruit le mineur possible et un refroidissement du moteur parfait. Le souffle d'air refroidissant est canalisé en circuits fixes. La capote est apte à être utilisée dans les ambiances tropicales. Le silencieux des gaz d'échappement, de type résidentiel, est mis à l'intérieur de la capote. La cabine est construite en acier galvanisé à chaud. Les tôles ont une épaisseur de 20/10. La structure est complètement boulonnée et fixée à travers des garnitures spéciales au polyéthylène. Tous les panneaux sont facilement amovibles. La cabine est dotée de portes avec grandes ouvertures qui permettent un accès facile au groupe électrogène pour les opérations de manutention. Les matériaux d'insonorisation sont fortement résistant au feu et auto-extinguibles.</p>	<p>La capota insonorizada TecnoGen Super Silent tiene sido planeada con el objetivo de alcanzar el menor nivel de rumorosidad posible y un perfecto enfriamiento del motor. El soplo de aire es canalizado en circuitos fijos. La cabina es apta a ser utilizada en ambientes tropicales. El silenciador de los gases de descargue, de tipo residencial, es colocado dentro de la cabina. La cabina es construida en acero cincado. Las chapas tienen un espesor de 20/10. La estructura es completamente bullonata y montada con sellos especiales de polietilene. Todos los paneles son fácilmente removibles. La cabina es dotada con puertas con amplias aberturas que permiten el fácil acceso al grupo electrogéno por las operaciones de manutención. Los materiales insonorizantes son muy resistentes al fuego y auto-extinguentes.</p>	<p>La cabina insonorizzata TecnoGen Super Silent è stata progettata allo scopo di raggiungere il minor livello di rumorosità possibile e un perfetto raffreddamento del motore. Il soffio d'aria raffreddante è canalizzato in circuiti fissi. La cabina è adatta ad essere utilizzata in ambienti tropicali. Il silenziatore dei gas di scarico, di tipo residenziale, è collocato all'interno della cabina. La cabina è costruita in acciaio zincato a caldo. Le lamiere hanno uno spessore di 20/10. La struttura è completamente bullonata e fissata tramite speciali sigilli al polietilene. Tutti i pannelli sono facilmente rimovibili. La cabina è dotata di porte con ampie aperture che consentono il facile accesso al gruppo elettrogeno per le operazioni di manutenzione. I materiali insonorizzanti sono altamente resistenti al fuoco e autoestinguenti.</p>
<b>Our quality in 13 points</b> <b>Notre qualité résumée en 13 points</b> <b>Nuestra calidad en 13 puntos</b> <b>La nostra qualità in 13 punti</b>			
<b>1</b>		Internal residential silencer for lower sound levels Silencieux interne pour un niveau bas de bruit Silenciador interno para un nivel de rumorosidad más bajo Silenziatore interno per un livello di rumorosità più basso	
<b>2</b>		Integrated fuel tank of different sizes Réservoirs de combustible disponibles, sur demande, de capacité supérieure Tanques integrados disponibles, como opción, de capacidad superior Serbatoi integrati disponibili, su richiesta, di capacità superiore	
<b>3</b>		Control panel viewing window to easily check status of generating set Fenêtre de visualisation du panneau de contrôle pour un contrôle plus facile du status opérationnel du groupe Ventana de visualización del panel de control por un más fácil control del estatus operativo del grupo Finestra di visualizzazione del pannello di controllo per un più facile controllo dello status operativo del gruppo	
<b>4</b>		Lockable access doors for extra safety and security Porte d'accès avec serrure pour une sûreté majeure Puertas de acceso con cerradura para una mayor seguridad Porte di accesso con serratura per una maggiore sicurezza	
<b>5</b>		Galvanized bolts Boulons galvanisés Pernos cincados Bulloni zincati	
<b>6</b>		Emergency stop button Interrupteur d'arrêt d'urgence Botón parada de emergencia Pulsante arresto di emergenza	
<b>7</b>		Fuel tank cap with external key Bouchon gasoil avec clé positionne à l'extérieur Tapo gasoleo con llave situado a l'externo Tappo gasolio con chiave posizionato all'esterno	
<b>8</b>		Fully banded baase frame Réservoir amovible avec bague de retention Tanque integrado sfilabile con el envase para recoger los líquidos Serbatoio integrato sfilabile con vasca raccolta liquidi	
<b>9</b>		Central lifting hook Crochet central d'enlèvement Gancho de elevación Gancio di sollevamento centrale	
<b>10</b>		Doors location convenient to controls and service area Placement des portes pour rendre les contrôles plus faciles Colocación de las puertas para facilitar los controles Collocazione delle porte per facilitare i controlli	
<b>11</b>		High serviceability level Haut niveau d'accessibilité pour la manutention Alto nivel de accesibilidad para la manutención Alto livello di accessibilità per la manutenzione	
<b>12</b>		Large cable entry area for easy installation Grande zone d'entré des câbles pour une installation plus facile Amplia área de entrada cables para una instalación fácil Ampia area di entrata cavi per una facile installazione	
<b>13</b>		Galvanized metal steel sheet pre-treated prior to powder coating Tôles en acier galvanisé pré-traitées avant le vernissage à poudre Chapas de acero cincado pre-tratadas antes de la pintura a polvo Lamiere di acciaio zincato pre-trattate prima della verniciatura a polvere	

**SOUND PROOF VERSION DRAWING  
DESSIN VERSION INSONORIZEE  
DIBUJO VERSION INSONORISADA  
DISEGNO VERSIONE INSONORIZZATA**

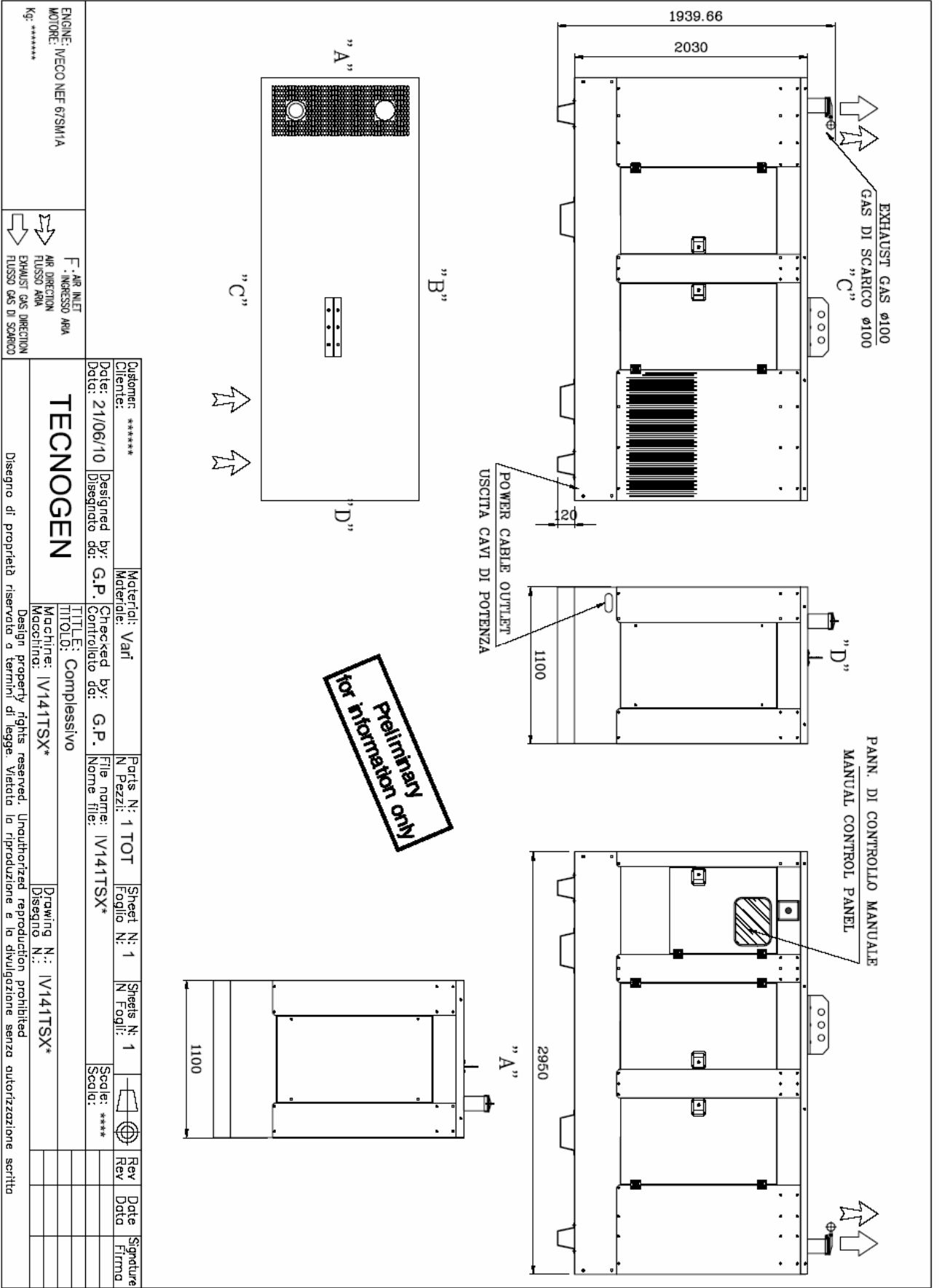

# N67 SM1

121 kW@1500 rpm

138 kW@1800 rpm

## Specifications

Thermodynamic cycle	Diesel 4 stroke, D.I.		
Air intake	TC		
Arrangement	6, in line		
Bore x Stroke	mm	104 x 132	
Total displacement	l	6.7	
Valves per cylinder	2		
Injection system	mechanical		
Speed governor	mechanical		
Cooling system	liquid (water + 50% Paraflu11)		
Flywheel housing/flywheel	type	SAE3 / 11" 1/2	
Flywheel rotation	CCW		
Lube oil specifications	ACEA E3-E5		
Lube oil consumption	<0.1% of fuel consumption		
Fuel specifications	EN 590		
Oil and filters intervals for replacement	hours	600	
Fuel consumption at:	rpm	1500	1800
	100% load l/h (g/kWh)	28.8 (212.5)	33.9 (216.3)
	80% load l/h (g/kWh)	23.2 (214.0)	27.5 (219.4)
	50% load l/h (g/kWh)	14.6 (216.3) 1	8.3 (233.2)
Coolant capacity: engine only	l	~10.5	
	engine+radiator	l	~40.5
ATB (without canopy)	°C	51	
<b>No remote cooling radiator allowed</b>			
Lube oil total system capacity including pipes, filters etc.	l	~17.2	
Electrical system	12Vcc		
Starting batteries: recommended capacity	Ah	1x100	
Discharge current (EN 50342)	A	800	
Cold starting: without air preheating	°C	-15	
	with air preheating	°C	-25

## Performances

Ratings <sup>1</sup>		1500 rpm		1800 rpm	
		PRIME	STAND-BY	PRIME	STAND-BY
Rated Output <sup>2</sup>	kWm	110	121	126	138

1) Ratings in accordance with ISO 8528. For duty at temperature over 40°C and/or altitude over 1000 meters must be considered a power derating factor. Contact the FPT sales organization.

2) Net power at flywheel available after 50 hours running with a ±3% tolerance.

**PRIME POWER:** The prime power is the maximum power available with varying loads for an unlimited number of hours. The average power output during a 24h period of operation must not exceed 80% of the declared prime power between the prescribed maintenance intervals and at standard environmental conditions. A 10% overload is permissible for 1 hour every 12 hours of operation.

**STAND-BY POWER:** The stand-by power is the maximum power available for a period of 500 hours/year with a mean load factor of 90% of the declared stand-by power. No kind of overloads is permissible for this use.

**CONTINUOUS POWER:** Contact the FPT sales organization.



## Standard configuration

FPT engine N67 SM1 equipped with:

- Mounted radiator
- Mounted belt driven pusher fan
- Fan guard
- Mounted air filter with replaceable cartridges
- Fuel filter
- Primary fuel filter/water separator
- Replaceable oil filter
- Front engine mounting brackets
- Flywheel housing SAE3 and flywheel 11" 1/2
- Re-directable exhaust gas elbow
- Recircled oil breather system
- Oil dipstick
- HWT and LOP sensors
- 12Vdc electrical system
- User's handbook

THE ENGINE IS SUPPLIED WITHOUT LIQUIDS

## Optional equipment:

On request the engine can be supplied with:

- Oil drain pump
- Oil drain valve
- 120/230 Volt water jacket heater
- WT and OP sensors for gauges
- Low water level sensor
- Turbo and exhaust gas guards
- Exhaust gas flexible joint
- 24Vdc electrical system
- Front radiator guard
- Electronic speed governor

## Overall dimensions:

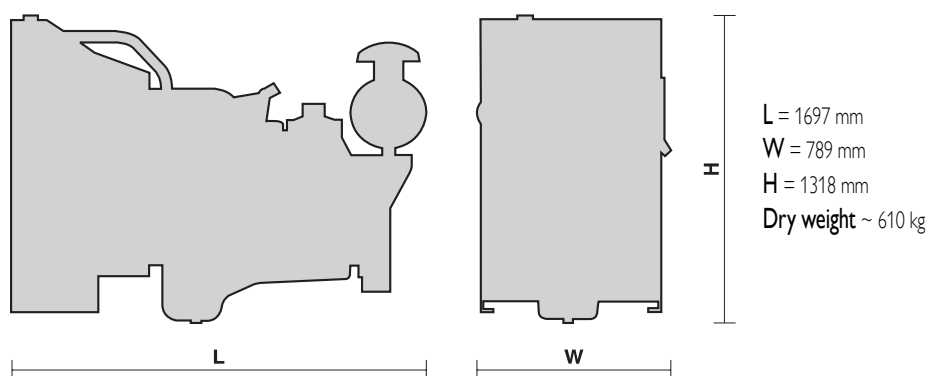

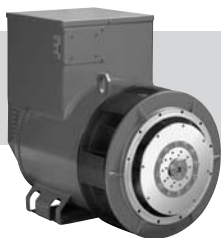

COMPANY  
WITH QUALITY SYSTEM  
CERTIFIED BY DNV  
ISO 9001

# ECP 34

MECCALTE spa - Via Roma, 20 - 36051 CREAZZO (VI) ITALIA  
Tel. 0444/396111 - Fax 0444/396166 - e-mail : mecc-alte-spa@meccalte.it  
web site: www.meccalte.com

## 4 POLE

### CARATTERISTICHE / CHARACTERISTICS / CARACTERISTIQUES / TECHNISCHE MERKMALE / CHARACTERISTICS

#### INDUSTRIAL RATINGS

ambient 40° C

Type	KVA - cos φ 0.8 - 3 Phase continuous							RENDIMENTI - EFFICIENCY - RENDEMENT WIRKUNGSGRAD - RENDIMIENTOS		
	CL. H (ΔT= 125°C)				CL. F (ΔT= 105°C)			η % CL. H (ΔT= 125°C)		
Series Star Y	380	400	415	IP45 400 V	380	400	415	2/4	3/4	4/4
Parallel Star YY	190	200	208		190	200	208			
Series Delta Δ	220	230	240		220	230	240			
Parallel Delta ΔΔ	110	115	120		110	115	120			
<b>ECP34-1S/4</b>	85	<b>85</b>	85	65	77	<b>77</b>	77	90	91,9	91,5
<b>ECP34-2S/4</b>	105	<b>105</b>	105	85	95	<b>95</b>	95	90,7	92,5	92,2
<b>ECP34-1L/4</b>	130	<b>130</b>	130	104	118	<b>118</b>	118	91,5	93,2	92,7
<b>ECP34-2L/4</b>	150	<b>150</b>	150	120	136	<b>136</b>	136	92	93,5	93,2

60 Hz	CL. H (ΔT= 125°C)				CL. F (ΔT= 105°C)			RENDIMENTI - EFFICIENCY - RENDEMENT WIRKUNGSGRAD - RENDIMIENTOS		
								η % CL. H (ΔT= 125°C)		
Series Star Y	440	460	480	IP45 480 V	440	460	480	2/4	3/4	4/4
Parallel Star YY	220	230	240		220	230	240			
Series Delta Δ	254	265	277		254	265	277			
Parallel Delta ΔΔ	127	133	138		127	133	138			
<b>ECP34-1S/4</b>	102	102	<b>102</b>	78	92	92	<b>92</b>	91,8	93,8	93,4
<b>ECP34-2S/4</b>	126	126	<b>126</b>	102	114	114	<b>114</b>	92,3	94,1	93,8
<b>ECP34-1L/4</b>	145	156	<b>156</b>	125	130	141	<b>141</b>	93,3	94,9	94,4
<b>ECP34-2L/4</b>	170	180	<b>180</b>	144	150	163	<b>163</b>	93,8	95,2	95

#### MARINE RATINGS ΔT = 90°C

ambient 45° C

Type	50 Hz 3 Phase continuous						60 Hz 3 Phase continuous					
	KVA - cos φ 0.8			RENDIMENTI - EFFICIENCY - RENDEMENT WIRKUNGSGRAD - RENDIMIENTOS η %			KVA - cos φ 0.8			RENDIMENTI - EFFICIENCY - RENDEMENT WIRKUNGSGRAD - RENDIMIENTOS η %		
Series Star Y	380	400	415	2/4	3/4	4/4	440	460	480	2/4	3/4	4/4
Parallel Star YY	190	200	208				220	230	240			
Series Delta Δ	220	230	240				254	265	277			
Parallel Delta ΔΔ	110	115	120				127	133	138			
<b>ECP34-1S/4</b>	72	<b>72</b>	72	89,3	91,2	91,9	86	86	<b>86</b>	91,1	93	96,8
<b>ECP34-2S/4</b>	88	<b>88</b>	88	90	91,8	92,5	106	106	<b>106</b>	91,6	93,4	94,1
<b>ECP34-1L/4</b>	110	<b>110</b>	110	90,9	92,7	93,2	126	132	<b>132</b>	92,5	94,4	94,9
<b>ECP34-2L/4</b>	126	<b>126</b>	126	91,4	92,9	93,5	145	151	<b>151</b>	93,3	94,6	95,2

Type	J (Kgm <sup>2</sup> ) B3-B14 FORM	Peso/Weight Poids/Gewicht MD35 (Kg)	Vol. d'aria/Air Vol./Vol. d'air Luftmenge/Vol. de aire		Rumore - Noise - Bruit - Geräusch - Ruido dB(A)			
			50 Hz (m <sup>3</sup> /min)	60 Hz (m <sup>3</sup> /min)	50 Hz		60 Hz	
					1m	7m	1m	7m
<b>ECP34-1S/4</b>	0,7663	341	19,3	23	79	65	83	69
<b>ECP34-2S/4</b>	0,9415	419						
<b>ECP34-1L/4</b>	1,0313	445						
<b>ECP34-2L/4</b>	1,1863	491						

Dati di targa / Rating / Données pour plaque  
Angaben auf dem Schild / Características nominales



**DATI ELETTRICI TIPICI / TYPICAL ELECTRICAL DATA / DONNEES ELECTRIQUES  
TYPISCHE ELEKTRISCHE DATEN / DATOS GENERALES ELECTRICOS**

TIPO / TYPE / TYPE / TYP / TIPO		ECP 34-1S/4	ECP 34-2S/4	ECP 34-1L/4	ECP 34-2L/4
Potenza classe "F" / Rating "F" class Puissance class "F" / Leistung klasse "F" Potencia clase "F"	kVA 50 Hz	77	95	118	136
	kVA 60 Hz	92	114	141	163
Reattanza sincrona diretta / Direct - axis synchronous reactance / Reactance longitudinale synchrone / Direkte Synchronreaktanz / Reactancia sincrónica directa	X <sub>d</sub> %	325	230	214	240
Reattanza transitoria diretta / Direct - axis transient reactance / Reactance longitudinale transitoire / Direkte vorübergehende Reaktanz / Reactancia transitoria directa	X' <sub>d</sub> %	22,3	17,6	17,2	14,8
Reattanza subtransitoria diretta / Direct - axis subtransient reactance / Reactance longitudinale subtransitoire / Direkte momentane Reaktanz / Reactancia subtransitoria directa	X'' <sub>d</sub> %	7,4	5,7	6,8	6,2
Reattanza sincrona in quadratura diretta / Quadrature - axis synchronous reactance / Reactance transversale synchrone / Um 90° verschobene Synchronreaktanze / Reactancia sincrónica en cuadratura	X <sub>q</sub> %	170,5	149,6	147,6	122,1
Reattanza transitoria in quadratura / Quadrature - axis transient reactance / Reactance transversale transitoire / Um 90° verschoben vorübergehende Reaktanz / Reactancia transitoria en cuadratura	X' <sub>q</sub> %	170,5	149,6	147,6	122,1
Reattanza subtransitoria in quadratura / Quadrature - axis subtransient reactance / Reactance transversale subtransitoire / Um 90° verschoben momentane Reaktanz / Reactancia subtransitoria en cuadratura	X'' <sub>q</sub> %	29,5	31,2	29,9	26,5
Reattanza di sequenza inversa / Negative - sequence reactance / Reactance inverse / Gegenereaktanz / Reactancia de sequencia inversa	X <sub>2</sub> %	19,2	18,5	18,5	16,5
Reattanza di sequenza zero / Zero sequence reactance / Reactance homopolaire / Null - Phasenfolge Reaktanz / Reactancia de secuencia cero	X <sub>0</sub> %	3,6	3,5	2,9	2,5
Costante di tempo transitoria / Transient time constant / Constante de temps transitoire / Vorübergehende Zeitkonstante / Constante de tiempo transitoria	T' <sub>d</sub> (ms)	41,92	39,3	37,2	40,1
Costante di tempo subtransitoria / Subtransient time constant / Constante de temps subtransitoire / Momentane Zeitkonstante / Constante de tiempo subtransitoria	T'' <sub>d</sub> (ms)	5,75	5,5	7,6	9,5
Costante di tempo unidirezionale / Armature time constant / Constante de temps d'armature / Einseitig gerichtete Zeitkonstante / Constante de tiempo unidireccional	T <sub>α</sub> (ms)	15,4	14,6	16,3	17
Costante di tempo a vuoto / Open circuit time constant / Constante de temps transitoire à vide / Leerlauf - Zeitkonstante / Constante de tiempo en vacio	T' <sub>do</sub> (s)	1,5	1,7	1,8	1,9
Rapporto di cortocircuito / Short - circuit ratio / Rapport de court circuit / Kurzschlussverhältnis / Relación de cortocircuito	K <sub>cc</sub>	0,5	0,47	0,49	0,48
Resistenza di avvolgimento statore / Stator winding resistance / Résistance de bobinage du stator / Wicklungswiderstand / Resistencia de bobinado estator	Ω 1 - 2 20 °C	0,03	0,02	0,018	0,015

REGULATOR		PARALLEL DEVICE	THERMAL PROTECTION			HEATERS	MECHANICAL PROTECTION			
SR7/2	UVR6		PTC	BIMET DEVICE	PT100		IP21	IP23	IP45	IP55
●	□	□	□	□	□	●	□	□	□	

● = Standard      □ = Optional

# DSECONTROL<sup>®</sup> MONITORING WITH INTELLIGENCE.



## DSE7310 & DSE7320

AUTO START & AUTO MAINS FAILURE CONTROL MODULES (COMMUNICATIONS & EXPANSION)



The DSE7310 and DSE7320 are new control modules for single gen-set applications. The modules have been developed from the successful DSE5310 and DSE5320 Series and incorporate a number of advanced features to meet the most demanding on-site applications.

The DSE7310 is an Automatic Start Control Module and the DSE7320 is an Auto Mains (Utility) Failure Control Module. Both modules have been designed to start and stop diesel and gas generating sets that include electronic and non-electronic engines. The DSE7320 includes the additional capability of being able to monitor a mains (utility) supply.

Both modules include USB, RS232 and RS485 ports as well as dedicated DSENet<sup>®</sup> terminals for expansion device connectivity.

The modules are simple to operate and feature a newly designed menu layout for improved clarity. Enhanced features include a real time clock for enhanced event and performance monitoring, ethernet communications for low cost monitoring, mutual standby to reduce engine wear and tear, trend analysis to assist in the detection of patterns in engine status and preventative maintenance designed to detect if engine parts have developed fault conditions so they can be replaced before a major problem occurs.

### FEATURES

- Backed up real time clock
- 132 x 64 pixel LCD display
- Configurable display languages
- USB connectivity
- Robust module enclosure
- Five-key menu navigation
- Durable soft touch membrane buttons
- Fully configurable via PC software
- LED and LCD alarm indication
- Engine exercise mode
- Configurable start & fuel outputs
- kWh monitoring
- Automatic load transfer
- Eight configurable digital inputs
- Six configurable outputs
- Configurable timers and alarms
- Modbus RTU
- Magnetic pick-up
- Front panel programming
- Multiple date and time exercise scheduler
- SMS messaging
- Power save mode
- PIN protected programming
- User selectable RS232 & RS485 communications
- DSENet<sup>®</sup> compatible
- Ethernet communications via DSE860/865
- Customer logo display capability
- Multiple date and time maintenance scheduler
- Configurable display pages
- Programmable load shedding/acceptance
- Trend analysis
- Preventative maintenance
- kW overload protection
- Unbalanced load protection
- PDA compatible PC software
- Flexible sender input
- Configurable SCADA output page

### NEW FEATURES

- True dual mutual standby with load balancing timer
- Fan control for additional cooling
- 'Protections Disabled' facility
- Fuel usage monitoring and low fuel alarm
- Support for up to three remote display units
- Automatic sleep mode
- Easy access, configurable diagnostics page shows summary of output states
- Improved programmable event log (250) showing date and time
- Manual fuel pump control
- Alternative configuration
- Multiple date and time scheduler
- 3 Programmable Maintenance alarms with comms alert
- Customisable status screens
- Low fuel level alarm delay
- Charge alternator fail warning and shutdown alarms with user programmable delay
- Independent Earth fault trip
- Sleep mode
- Load switching (Load shedding and dummy load outputs)
- Manual speed trim (on CAN engines that support this feature)
- Additional display screens to help with modern diagnostics
- Security levels – PC software has password system to control access to PC software features
- Operator configurable virtual LEDs visible in SCADA

### SPECIFICATION

#### DC SUPPLY

**CONTINUOUS VOLTAGE RATING**  
8V to 35V Continuous

**CRANKING DIP PROTECTION**  
Able to survive 0V for 50mS, providing supply was at least 10V before dropout and supply recovers to 5V. This is achieved without the need for internal batteries

**CHARGE FAIL/ EXCITATION**  
0V to 35V fixed power source 2.5W

**MAXIMUM STANDBY CURRENT**  
160mA at 12V 80mA at 24V

**MAXIMUM OPERATING CURRENT**  
340mA at 12V 160mA at 24V

#### ALTERNATOR INPUT

**RANGE**  
15V - 333V (L-N) 50Hz - 60Hz  
(Minimum 15V AC Ph-N)

**ACCURACY**  
1% of full scale true RMS sensing

**SUPPORTED TOPOLOGIES**  
3 phase 4 wire  
3 phase 3 wire  
Single phase 2 wire  
2 phase 3 wire L1 & L2  
2 phase 3 wire L1 & L3

#### MAINS/UTILITY INPUT (DSE7320 ONLY)

**RANGE**  
15V - 333V (L-N) 50Hz - 60Hz  
(Minimum 15V AC Ph-N)

**ACCURACY**  
1% of full scale true RMS sensing

**SUPPORTED TOPOLOGIES**  
3 phase 4 wire  
3 phase 3 wire  
Single phase 2 wire  
2 phase 3 wire L1 & L2  
2 phase 3 wire L1 & L3

#### CT'S

**BURDEN**  
0.5VA

**PRIMARY RATING**  
1A - 8000A (user selectable)

**SECONDARY RATING**  
1A or 5A secondary (user selectable)

**ACCURACY OF MEASUREMENT**  
1% of full load rating

**RECOMMENDATIONS**  
Class 1 required for instrumentation  
Protection class required if using for protection

## SPECIFICATION

### MAGNETIC PICKUP

#### VOLTAGE RANGE

+/- 0.5V minimum (during cranking) to 70V peak

#### FREQUENCY RANGE

10,000 Hz (max)

### RELAY OUTPUTS

#### OUTPUT A (FUEL)

15 Amp DC at supply voltage

#### OUTPUT B (START)

15 Amp DC at supply voltage

#### OUTPUTS C & D

8 Amp 250V (Volt free)

#### AUXILIARY OUTPUTS E,F,G,H

2 Amp DC at supply voltage

### DIMENSIONS

#### OVERALL

240mm x 181.1mm x 41.7mm  
9.4" x 7.1" x 1.6"

#### PANEL CUT-OUT

220mm x 160mm  
8.7" x 6.3"  
Max panel thickness 8mm (0.3")

## TESTING STANDARDS

### ELECTRICAL SAFETY/ ELECTROMAGNETIC COMPATIBILITY

#### BS EN 60950

Safety of Information Technology Equipment, including Electrical Business Equipment

#### BS EN 61000-6-2

EMC Generic Immunity Standard (Industrial)

#### BS EN 61000-6-4

EMC Generic Emission Standard (Industrial)

### ENVIRONMENTAL

#### BS EN 60068-2-1

Cold Temperature -30°C

#### BS EN 60068-2-2

Hot Temperature +70°C

#### BS EN60068-2-30 HUMIDITY

Test Db cyclic  
93% RH @ 40°C for 48 hours

#### BS EN 60068-2-6 VIBRATION

10 sweeps at 1 octave/minute in each of 3 major axes  
5Hz to 8Hz @ +/-7.5mm constant displacement  
8Hz to 500Hz @ 2gn constant acceleration

#### BS EN 60068-2-27 SHOCK

3 half sine shocks in each of 3 major axes  
15gn amplitude, 11ms duration

#### BS EN 60529 DEGREES OF PROTECTION PROVIDED BY ENCLOSURES

- **IP65** (Front of module when installed into the control panel with the supplied sealing gasket)

#### NEMA RATING (APPROXIMATE)

- **12** (Front of module when installed into the control panel with the supplied sealing gasket)

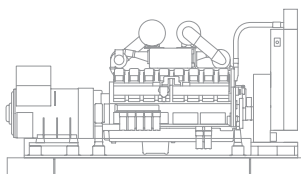

**ELECTRONIC ENGINE CAPABILITY**

## BENEFITS

- 132 x 64 pixel ratio makes information easy to read
- Real time clock provides accurate event logging
- PC software is license free
- Set maintenance periods can be configured to maintain optimum engine performance
- Ethernet communications provides advanced remote monitoring at low cost
- Modules can be integrated into building management systems
- Preventative maintenance avoids expensive engine down time
- Advanced PCB layout ensures high reliability
- Robust design
- Extensive performance monitoring

## OPERATION

The modules are operated via the START, STOP, AUTO and MANUAL soft touch membrane buttons on the front panel. The DSE7320 also has a TEST button. Both modules include load switch buttons. The main menu system is accessed using the five navigation buttons to the left of the LCD display.

## CONFIGURATION

The modules can be configured using the front panel buttons or by using the PC software and a USB lead.

## COMMUNICATIONS

The DSE7310 & DSE7320 have a number of different communication capabilities.

## SMS Messaging

When the module detects an alarm condition, it has the ability to send an SMS message to a dedicated mobile number (s), notifying an engineer of the exact time, date and reason why the engine failed (GSM Modem and SIM Card required).

## Remote Communications

When the module detects an alarm state, it dials out to a PC notifying the user of the condition (Modem required).

## Remote Control

The module can be controlled remotely using either a GSM Modem, Ethernet via DSE860/865 or via RS485. Using a modem allows the module to be controlled from any distance. Using RS485 limits the distance to 1km (0.6 miles).

## Building Management

The module has been designed to be integrated into new and existing building management systems, using RS485.

## PC Software

The module has the ability to be configured and monitored from a remote PC, using the PC software and a USB lead.

## INPUTS & OUTPUTS

Analogue inputs are provided for oil pressure, coolant temperature and fuel level. These connect to conventional engine mounted resistive sender units to provide accurate monitoring and protection facilities. They can also be configured to interface with digital switch type inputs for low oil pressure and high coolant temperature shutdowns. Eight user configurable digital inputs are also included, plus one flexible sender.

Relays are provided for fuel solenoid output, start output and six additional configurable outputs. On these configurable outputs a range of different functions, conditions or alarms can be selected.

## INSTRUMENTATION

The modules provide advanced metering facilities, displaying the information on the LCD display. The information can be accessed using the five-key menu navigation to the left of the display.

7310	7320
<b>Generator Instruments</b> Volts, Hz, Amps, kW, kVA, Pf, kWh, kVAr, kVArh, KVAh	<b>Generator Instruments</b> Volts, Hz, Amps, kW, kVA, Pf, kWh, kVAr, kVArh, KVAh
<b>Engine Instruments</b> RPM, Oil Pressure, Coolant Temperature, Hours Run, Charging Voltage, Battery Volts.	<b>Engine Instruments</b> RPM, Oil Pressure, Coolant Temperature, Hours Run, Charging Voltage, Battery Volts.
<b>Electronic Engines</b> Enhanced Instrumentation and Engine ECU diagnostics via electronic engine interface.	<b>Electronic Engines</b> Enhanced instrumentation and Engine ECU diagnostics via electronic engine interface.
<b>Mains/Utility Instruments</b> Volts, Frequency, Amps (optional when CT's are fitted load side of the line)	<b>Mains/Utility Instruments</b> Volts, Frequency, Amps (optional when CT's are fitted load side of the line)

## RELATED MATERIALS

TITLE	PART NO'S
DSE7xxx Manual	057-074
DSE72xx/73xx PC Software Manual	057-077
DSE2130 Data Sheet	053-060
DSE2157 Data Sheet	053-061
DSE2548 Data Sheet	053-062
DSE860/865 Data Sheet	055-071

## DSENET®

DSENet® is a collection of expansion modules that have been created to work with DSENet® compatible control modules. DSENet® allows up to 20 different expansion devices to be used at a time. 10 of these devices can be of the same type (excluding DSE2130). The expansion modules available are:

## Available Now

DSE2157 Relay Output Expansion Module  
DSE2130 Input Expansion Module  
DSE2548 Annunciator Module  
Remote Display Module

## Coming Soon

FET Output Expansion Module  
NFPA 110 Interface Module  
Identification Dongle

## EVENT LOG

The module includes a comprehensive event log that shows the most recent 250 alarm conditions and the date and time that they occurred. This function assists the user when fault finding and maintaining a generating set.

## ELECTRONIC ENGINE COMPATIBILITY

- CAT
- Cummins
- Deutz
- John Deere
- MTU
- Perkins
- Scania
- Volvo
- IVECO
- Generic
- Plus additional manufacturers

# DSE7310 & DSE7320

