

TENAX V SERIES

DIESEL GENERATOR
GROUPE ELECTROGENE DIESEL
GRUPO ELECTROGENO DIESEL
GRUPPO ELETTOGENO DIESEL

MODEL
 MODELE
 MODELO
 MODELLO

VO 651 TV*

POWERED BY

OPEN VERSION

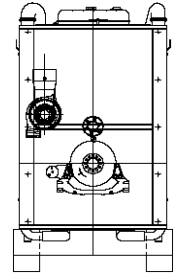
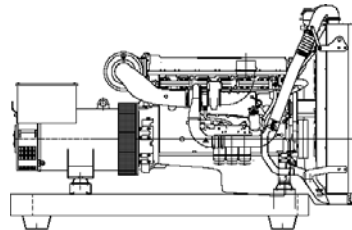

SOUNDPROOF VERSION

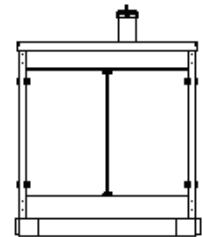
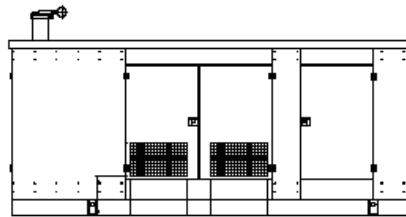

GENERATING SET PERFORMANCE PERFORMANCES DU GROUPE PRESTACIONES DEL GRUPO PRESTAZIONI DEL GRUPPO		50 Hz	60 Hz
Voltage Voltage Voltaje Tensione		V 400 / 230	V 220 / 127
Continuous Power Puissance service continue Potencia servicio continuo Potenza servizio continuo	PRP	kVA 550	kVA 625
Stand-by Power Puissance service secours Potencia servicio emergencia Potenza servizio in emergenza	LTP	kVA 600	kVA 690
Continuous Power Puissance service continue Potencia servicio continuo Potenza servizio continuo	PRP	kWe 440	kWe 500
Stand-by Power Puissance service secours Potencia servicio emergencia Potenza servizio in emergenza	LTP	kWe 480	kWe 552
Power factor Facteur de puissance Factor de potencia Fattore di potenza	cos φ	0,8	0,8
Fuel consumption Consommation combustible Consumo de combustible Consumo combustibile	70 %	l/h 76,7	l/h 89,5

ENGINE MOTEUR MOTOR MOTORE	VOLVO		TAD 1642 GE	
PERFORMANCE PERFORMANCES PRESTACIONES PRESTAZIONI	1500 rpm		1800 rpm	
Continuous Power Puissance service continue Potencia servicio continuo Potenza servizio continuo	PRP	kWm	485	kWm 532
Stand-by Power Puissance service secours Potencia servicio emergencia Potenza servizio in emergenza	LTP	kWm	536	kWm 585
Specific fuel consumption Consommation spécifique combustible Consumo específico de combustible Consumo specifico combustibile		g/kWh	25 % 218 50 % 201 75 % 195 100 % 200	g/kWh 25 % 229 50 % 202 75 % 197 100 % 206
Diesel 4 Stroke – Injection type Diesel 4 temps – Type injection Diesel 4 tiempos – Tipo de inyeccion Diesel a 4 tempi – Tipo di iniezione				Direct Directe Directa Diretta
Aspiration type Type d'aspiration Tipo de aspiracion Tipo d'aspirazione				Turbocharged Suraalimentée Sobrealimentato Sovralimentata
Cooling system Refroidissement Sistema de refrigeracion Raffreddamento				Water Eau Agua Acqua
Speed governor Régulateur de tours Regulador Regolatore di giri				Electronic Electronique Electronico Elettronico
Cylinders, numbers and arrangement Nombre et disposition des cylindres Cilindros, numero y disposicion Numero e disposizione dei cilindri				6L
Total displacement Cylindrée totale Cilindrata total Cilindrata totale				cm ³ 16.120
Bore x stroke Alésage x course Diámetro x carrera Alesaggio x corsa				mm 144 x 165
Compression ratio Rapport de compression Relación de compresión Rapporto di compressione				14.5 :1
Engine electric system voltage Voltage système électrique moteur Voltaje sistema eléctrico motor Voltaggio sistema elettrico motore				24 V
Derating for temperature Déclassement pour temperature Declasamiento para temperatura Declasseamento per temperatura				NO DERATING
Derating for altitude Déclassement pour altitude Declasamiento para altitud Declasseamento per altitudine				0÷1500 m 0 1500÷3000 m 5,5% / 500mt
Derating for relative humidity Déclassement pour humidité relative Declasamiento para humedad relativa Declasseamento per umidità relativa				NO DERATING

ALTERNATOR ALTERNATEUR ALTERNADOR ALTERNATORE		MECCALTE	
PERFORMANCE PERFORMANCES PRESTACIONES PRESTAZIONI		1500 rpm	1800 rpm
Model Modele Modelo Modello		ECO40-1L/4	ECO40-3S/4
Continuous Power Puissance service continue Potencia servicio continuo Potenza servizio continuo	40 °C	kVA 550 kWe 440	kVA 630 kWe 504
Stand-by Power Puissance service secours Potencia servicio emergencia Potenza servizio in emergenza	40 °C	kVA 567 kWe 454	kVA 625 kWe 500
Stand-by Power Puissance service secours Potencia servicio emergencia Potenza servizio in emergenza	27 °C	kVA 601 kWe 481	kVA 656 kWe 525
Efficiency Rendement Eficienza Efficienza		2/4 93,7 % 3/4 94,6 % 4/4 94,2 %	2/4 94,8 % 3/4 95,6 % 4/4 95,2 %
Standard winding connections Liaison des bobinages Tipo de conexión Collegamento avvolgimenti		Y	YY
Exciter Eccitatrice Excitador Eccitatrice	brushless rotating exciter design with solid state pivotante sans brosses avec pont de diodes pivotants puente de diodos sin escobillas rotantes rotante senza spazzole con ponte di diodi rotanti		
Poles Poles Polos Poli			4
Phases Phases Fases Fasi			3 + N
Wires Fils Hilos Morsetti			12
Voltage regulation Regulation Voltage Regulación voltaje Regolazione tensione			± 1%
Insulation class Classe d' isolation Classe de aislamiento Classe di isolamento			H
Enclosure Degré de protection mécanique Grado de protección mecánica Grado di protezione meccanica			IP 21
Air Volume Volume d'air Volumen de aire Volume d'aria		50 Hz 60 Hz	54 m ³ /min 64,8 m ³ /min
Standard AVR model Modele AVR standard Modelo AVR standard Modello AVR standard			DER-1
Derating for temperature Déclassement pour température Declasamiento para temperatura Declassamento per temperatura		0 ÷ 40°C > 40 °C	0 3 % / 5°C
Derating for altitude Déclassement pour altitude Declasamiento para altitud Declassamento per altitudine		0 ÷ 1000 m 1000 ÷ 2500 m 2500 ÷ 3000 m	0 3% / 500 m 4% / 500 m

LOGISTIC INFORMATION
INFORMATIONS LOGISTIQUES
INFORMATION LOGISTICA
INFORMAZIONI LOGISTICHE

	Integrated fuel tank capacity Capacité réservoir intergré Capacidad Tanque integrado Capacità Serbatoio integrato		Weight Poids Peso Peso	Dimensions Cotes d'encombrement Medidas externas Dimensioni d'ingombro		
	(L.)			(cm)		
	STD	EXTRA 1		(kg)	L	W
OPEN SKID VERSION VERSION SUR SKID VERSION ABIERTA VERSIONE APERTA	395	ON REQUEST	3800	322	120	200
SOUND PROOF VERSION VERSION INSONORISEE VERSION INSONORISADA VERSIONE INSONORIZATA	420	ON REQUEST	5680	485	200	244

GENSET STANDARD EQUIPMENT
EQUIPEMENT STANDARD GROUPE ELECTROGENE
EQUIPAMIENTO STANDARD GRUPO ELECTROGENO
EQUIPAGGIAMENTO STANDARD GRUPPO ELETTROGENO

GB	F	E	I
<ul style="list-style-type: none"> Steel base frame Vibration dampers Integrated fuel tank Silencer industrial type for open version Battery Manual autostart control panel With DSE7310 Engine with original tropical radiator Emergency stop button Sound proof canopy of galvanized steel with residential silencer 	<ul style="list-style-type: none"> Châssis acier Amortisseurs de vibrations Réservoir intégré Silencieux industriel pour la version ouverte Batterie Coffret de contrôle manuel autostart avec DSE7310 Moteur avec radiateur tropical Bouton arrêt d'urgence Capote d'insonorisation d'acier galvanisé avec silencieux résidentiel 	<ul style="list-style-type: none"> Telar de acero Apagadores de vibracion Tanque combustible Silenciador industrial para la versión abierta Bateria Cuadro electrico manual autostart con DSE7310 Motor con radiador original tropical Botón parada de emergencia Cabina de insonorización de acero cincado con silenciador residencial 	<ul style="list-style-type: none"> Basamento in acciaio Antivibranti Serbatoio integrato Silenziatore industriale per versione aperta Batteria Quadro elettrico manuale autostart con DSE7310 Motore con radiatore originale tropicalizzato Pulsante arresto di emergenza Cabina di insonorizzazione di acciaio zincato con marmitta residenziale

MANUAL AUTOSTART CONTROL PANEL
COFFRET ELECTRIQUE MANUEL AUTOSTART
CUADRO ELECTRICO MANUAL AUTOSTART
QUADRO ELETTRICO MANUALE AUTOSTART

ACP 7310 AUS

800 A (400 V - 3 ph - 50Hz - 1500 rpm)
2000 A (220 V - 3 ph - 60Hz - 1800 rpm)

STANDARD EQUIPMENT:	EQUIPEMENT STANDARD:	EQUIPAMIENTO STANDARD:	EQUIPAGGIAMENTO STANDARD:
4 poles circuit breaker Electronic control board DSE 7310 Control panel box key Emergency Stop button	Disjoncteur de protection 4 pôles Fiche électronique DSE 7310 Clé pour serrure du coffret Interrupteur d'arrêt d'urgence	Interruptor magnetotermico 4 polos Carta electronica DSE 7310 Llave cuadro Botón de parada de emergencia	Interruttore magnetotermico 4 poli Scheda elettronica DSE 7310 Chiave quadro Pulsante di arresto di emergenza



**DSE
7310**

CONTROL BOARD
CARTE ELECTRONIQUE DE CONTROL
CARTA ELETTRONICA DE CONTROL
SCHEDA ELETTRONICA DI CONTROLLO

PROTECTIONS	PROTECTIONS	PROTECCIONES	PROTEZIONI
Low oil pressure High engine temperature Low fuel level Fail to start Fail to stop Emergency stop Over/under generator frequency Over/under generator voltage Over/under speed Fuel level Belt breakage Over current Over/under battery voltage	Basse pression huile moteur Haute température moteur Basse niveau combustible Non démarrage Non arrêt Arrêt d'urgence Sur/sous générateur fréquence Sur/sous générateur voltage Sur/sourvitesse Niveau de combustible Rupture courroie Surcourant Sur/sus la tension de batterie	Baja presión aceite Elevada temperatura motor Baja nivel carburante Falta de arranque Falta de parada Parada de emergencia Sobre/bajo generatore frecuencia Sobre/bajo generatore voltaje Sobre/bajo velocidad nivel de combustible Ruptura correa Corriente maxima Sobre/bajo voltaje de la batería	Bassa pressione olio Alta temperatura motore Basso livello di carburante Mancato avviamento Mancato arresto Stop d'emergenza Sovra/sotto frequenza generatore Sovra/sotto voltaggio generatore Sovra/sotto velocità Livello del carburante Rottura cinghia Sovraccorrente Sovra/sotto tensione della batteria
DIGITAL METERS	VOYANT NUMERIQUE POUR	VISOR DIGITAL PARA	MISURATORE DIGITALE PER
Generator volts (3 phases) Generator amperes (3 phases) Generator frequency KW-meter kVA-meter Cos φ- meter Rpm meter Gen set hours counter Battery Volts	Voltmètre générateur (3 phases) Ampèremètre générateur (3 phases) Fréquencemètre générateur KW-mètre kVA- mètre Cos φ- mètre Tm mètre Totalisateur d'heures de marche Voltmètre batterie	Voltmetro (3 fases) Amperimetro (3 fases) Frecuencimetro KW- metro kVA- metro Cos φ-metro Revoluciones por minuto metro Medida horas de marcha Voltmetro batería	Voltmetro tensione generatore (3 fasi) Amperometro generatore (3 fasi) Frequenzimetro generatore KW- metro kVA- metro Cos φ-metro Gm metro Contaore di funzionamento gruppo Voltmetro batteria

AUTOMATIC CONTROL PANEL
COFFRET ELECTRIQUE AUTOMATIQUE
CUADRO ELECTRICO AUTOMATICO
QUADRO ELETTRICO AUTOMATICO

<p>1)</p> <p>ACP 7320 ATS</p> 	<p>COMPLETE CONTROL PANEL FREE STANDING TYPE Equipment: control board, circuit breaker, battery charger, transfer switch, box key. COFFRET ELECTRIQUE COMPLET TYPE ARMOIRE SEPRE DU GROUPE Equipement : carte électronique de contrôle, disjoncteur de protection, chargeur de batterie, inverseur de source, clé coffret. CUADRO ELECTRICO COMPLETO EN ARMARIO SEPARADO DEL GRUPO Equipamiento: carta electronica de controllo, interruptor magnetotermico, cargador de bateria, transferencial, llave quadro. QUADRO ELETTRICO COMPLETO SEPARATO DAL GRUPPO Equipaggiamento: scheda elettronica di controllo, interruttore magnetotermico, carica batteria, telecommutazione e chiave quadro.</p>
<p>2)</p> <p>ACP 7320 AMF</p> 	<p>AMF CONTROL PANEL FITTED ON THE GEN-SET WITHOUT TRANSFER SWITCH Equipment: control board, circuit breaker, battery charger, box key. COFFRET ELECTRIQUE MONTE SUR LE GROUPE SANS INVERSEUR DE SOURCE Equipement : carte électronique de contrôle, disjoncteur de protection, chargeur de batterie, clé coffret. CUADRO ELECTRICO MONTADO SOBRE EL GRUPO SIN TRANSFERENCIAL Equipamiento: carta electronica de controllo, interruptor magnetotermico, cargador de bateria, llave quadro. QUADRO ELETTRICO MONTATO SUL GRUPPO ELETTROGENO SENZA TELECOMMUTAZIONE Equipaggiamento: scheda elettronica di controllo, interruttore magnetotermico, carica batteria, chiave quadro.</p>
<p>3)</p> <p>ACP 7320 STS</p> 	<p>CONTROL PANEL FITTED ON THE GEN-SET WITH TRANSFER SWITCH SUPPLIED IN A SEPARATED BOX Equipment: control board, circuit breaker, battery charger, box key, separate transfer switch. COFFRET ELECTRIQUE MONTE SUR LE GROUPE + INVERSEUR DE SOURCE FOURNI DANS UN COFFRET SEPRE Equipement : carte électronique de contrôle, disjoncteur de protection, chargeur de batterie, inverseur de source séparé, clé coffret. CUADRO ELECTRICO MONTADO SOBRE EL GRUPO CON TRANSFERENCIAL SEPARADO Equipamiento: carta electronica de controllo, interruptor magnetotermico, cargador de bateria, llave quadro, transferencial separado. QUADRO ELETTRICO MONTATO SUL GRUPPO ELETTROGENO CON TELECOMMUTAZIONE SEPARATA Equipaggiamento: scheda elettronica di controllo, interruttore magnetotermico, carica batteria, chiave quadro, telecommutazione in armadio separato.</p>

 **DSE 7320**
CONTROL BOARD
CARTE ELECTRONIQUE DE CONTROL
CARTA ELECTRONICA DE CONTROL
SCHEDA ELETTRONICA DI CONTROLLO

GB	F	E	I
<p>The DSE7320 is an Automatic Mains Failure Control Module designed to automatically start and stop diesel generating sets that include electronic and non electronic engines. The module also provides excellent genset monitoring and protection features.</p>	<p>La DSE7320 est une carte de contrôle projetée pour démarrer et arrêter automatiquement groupes électrogènes diesels avec moteurs électroniques et non électroniques. La carte représente un système excellent de contrôle et de protection du groupe électrogène.</p>	<p>La DSE7320 es una carta de control para arranque y parar automáticamente grupos electrógenos diesel con motores electrónicos y no electrónicos. La carta constituye un excelente sistema de control y protección del grupo electrógeno.</p>	<p>La DSE7320 è una scheda di controllo progettata per avviare e arrestare automaticamente gruppi elettrogeni diesel con motori elettronici e non elettronici. La scheda costituisce un eccellente sistema di controllo e di protezione del gruppo elettrogeno.</p>
FEATURES	EQUIPEMENT	EQUIPMENT	EQUIPAGGIAMENTO
<p>Stop/reste – Auto – Manual – Start LCD display scroll Event log view Acoustic alarm</p>	<p>Fiche électronique de contrôle DSE7320 Disjoncteur de protection Chargeur de batterie Bouton poussoir arrête d'urgence</p>	<p>Ficha electrónica de control DSE7320 Interruptor magnetotermico Cargador de bateria Boton de parada de emergencia</p>	<p>Scheda elettronica di controllo DSE7320 Interruttore magnetotermico Carica batteria Pulsante stop emergenza</p>
DIGITAL MEASURING	MESURES NUMERIQUES	MEDIDAS DIGITALES	MISURAZIONI DIGITALI
<p>Generator volts (3 phases) Generator amperes (3 phases) Generator frequency KW-meter kVA-meter Cos φ- meter Rpm meter Water temperature (optional) Oil pressure (optional) Gen set hours counter Mains volts Battery volts Mains frequency Charging voltage Start-counter Fuel level %</p>	<p>Voltmètre générateur (3 phases) Ampèremètre générateur (3 phases) Fréquencemètre générateur KW- mètre kVA- mètre Cos φ- mètre Tm mètre Température eau (facultatif) Pression huile (facultatif) Totalisateur d'heures de marche Voltmètre secteur Voltmètre batterie Fréquence réseau Tension de charge Compteur démarrages Niveau combustible %</p>	<p>Voltmetro (3 fases) Amperimetro (3 fases) Frecuencimetro KW- metro kVA- metro Cos φ- metro Revoluciones por minuto metro Termometro agua (opcional) Presión aceite (opcional) Medida horas de marcha Voltmetro tensión de red Voltmetro batería Frecuencia red Tensión de carga Numero de arranques Nivel carburante %</p>	<p>Voltmetro tensione generatore (3 fasi) Amperometro generatore (3 fasi) Frequenzimetro generatore KW- metro kVA- metro Cos φ- metro Gm metro Temperatura acqua (facoltativo) Pressione olio (facoltativo) Contaore di funzionamento gruppo Voltmetro tensione rete Voltmetro batteria Frequenza rete Tensione di carica Contavviamenti Livello carburante %</p>
INDICATORS	INDICATEURS	INDICADORES	INDICATORI
<p>Mains live Generator live Mains contactor closed Generator contactor closed Engine running</p>	<p>Présence secteur Présence tension générateur Inverseur secteur fermé Inverseur générateur fermé Moteur en marche</p>	<p>Presencia tensión de red Presencia tensión grupo Transferencial red cerrado Transferencial grupo cerrado Motor en marcha</p>	<p>Presenza tensione di rete Presenza tensione generatore Erogazione da rete Erogazione da gruppo Motore avviato</p>
PROTECTIONS	PROTECTIONS	PROTECCIONES	PROTEZIONI
<p>Low oil pressure High engine temperature Low fuel level Fail to start Fail to stop Emergency stop Over/under frequency Over/under voltage Over/under speed Fuel level Belt breakage Over current Over/under battery voltage</p>	<p>Bas pression huile moteur Haute température moteur Bas niveau combustible Non démarrage Non arrêt Arrêt d'urgence Sur/sous fréquence Sur/sous voltage Sur/sous vitesse Niveau de combustible Rupture courroie Surcourant Sur/sus la tension de batterie</p>	<p>Baja presión aceite Elevada temperatura motor Baja nivel carburante Falta de arranque Falta de parada Parada de emergencia Sobre/bajo frecuencia Sobre/bajo voltaje Sobre/bajo velocidad nivel de combustible Ruptura correa Corriente maxima Sobre/bajo voltaje de la batería</p>	<p>Bassa pressione olio Alta temperatura motore Basso livello di carburante Mancato avviamento Mancato arresto Stop d'emergenza Sovra/sotto frequenza Sovra/sotto voltaggio Sovra/sotto velocità Livello del carburante Rottura cinghia Sovracorrente Sovra/sotto tensione della batteria</p>

SOUNDPROOF CANOPY
CAPOTE D'INSONORISATION
CAPOTA DE INSONORIZACION
CABINA INSONORIZZATA

GB	F	E	I
<p>The TecnoGen Super Silent soundproof canopy has been designed with the aim of achieving the maximum noise level reduction and to provide a perfect cooling of the engine. The cooling airflow is forced through fixed circuits. The canopy is suitable for tropical ambient application. The exhaust gas silencer is residential type internally mounted. The canopy is completely built of hot galvanized carbon sheet steel. The sheets have a thickness 20/10. The structure is fully bolted, fixed by a special polyethylene sealing, completely free from electrical installation. All the panels can be easily removed. The cab is provided with doors of wide opening for easy access to generating set for the maintenance operations. The soundproofing materials are highly fire resistant and self-extinguishing.</p>	<p>La capote insonorisée TecnoGen Super Silent à été conçue pour atteindre le niveau de bruit le mineur possible et un refroidissement du moteur parfait. Le souffle d'air refroidissant est canalisé en circuits fixes. La capote est apte à être utilisée dans les ambiances tropicales. Le silencieux des gaz d'échappement, de type résidentiel, est mis à l'intérieur de la capote. La cabine est construite en acier galvanisé à chaud. Les tôles ont une épaisseur de 20/10. La structure est complètement boulonnée et fixée à travers des garnitures spéciales au polyéthylène. Tous les panneaux sont facilement amovibles. La cabine est dotée de portes avec grandes ouvertures qui permettent un accès facile au groupe électrogène pour les opérations de manutention. Les matériaux d'insonorisation sont fortement résistant au feu et auto-extinguibles.</p>	<p>La capota insonorizada TecnoGen Super Silent tiene sido planeada con el objetivo de alcanzar el menor nivel de rumorosidad posible y un perfecto enfriamiento del motor. El soplo de aire es canalizado en circuitos fijos. La cabina es apta a ser utilizada en ambientes tropicales. El silenciador de los gases de descargue, de tipo residencial, es colocado dentro de la cabina. La cabina es construida en acero cincado. Las chapas tienen un espesor de 20/10. La estructura es completamente bullonata y montada con sellos especiales de polietilene. Todos los paneles son fácilmente removibles. La cabina es dotada con puertas con amplias aberturas que permiten el fácil acceso al grupo electrógeno por las operaciones de manutención. Los materiales insonorizantes son muy resistentes al fuego y auto-extinguentes.</p>	<p>La cabina insonorizzata TecnoGen Super Silent è stata progettata allo scopo di raggiungere il minor livello di rumorosità possibile e un perfetto raffreddamento del motore. Il soffio d'aria raffreddante è canalizzato in circuiti fissi. La cabina è adatta ad essere utilizzata in ambienti tropicali. Il silenziatore dei gas di scarico, di tipo residenziale, è collocato all'interno della cabina. La cabina è costruita in acciaio zincato a caldo. Le lamiere hanno uno spessore di 20/10. La struttura è completamente bullonata e fissata tramite speciali sigilli al polietilene. Tutti i pannelli sono facilmente rimovibili. La cabina è dotata di porte con ampie aperture che consentono il facile accesso al gruppo elettrogeno per le operazioni di manutenzione. I materiali insonorizzanti sono altamente resistenti al fuoco e autoestinguenti.</p>

Our quality in 10 points
Notre qualité résumée en 10 points
Nuestra calidad en 10 puntos
La nostra qualità in 10 punti

1	Internal residential silencer for lower sound levels Silencieux interne pour un niveau bas de bruit Silenciador interno para un nivel de rumorosidad más bajo Silenziatore interno per un livello di rumorosità più basso
2	Integrated fuel tank of different sizes Réservoirs de combustible disponibles, sur demande, de capacité supérieure Tanques integrados disponibles, como opción, de capacidad superior Serbatoi integrati disponibili, su richiesta, di capacità superiore
3	Control panel viewing window to easily check status of generating set Fenêtre de visualisation du panneau de contrôle pour un contrôle plus facile du status opérationnel du groupe Ventana de visualización del panel de control por un más fácil control del estatus operativo del grupo Finestra di visualizzazione del pannello di controllo per un più facile controllo dello status operativo del gruppo
4	Lockable access doors for extra safety and security Porte d'accès avec serrure pour une sûreté majeure Puertas de acceso con cerradura para una mayor seguridad Porte di accesso con serratura per una maggiore sicurezza
5	Galvanized bolts Boulons galvanisés Pernos cincados Bulloni zincati
6	Emergency stop button Interrupteur d'arrêt d'urgence Botón parada de emergencia Pulsante arresto di emergenza
7	Doors location convenient to controls and service area Placement des portes pour rendre les contrôles plus faciles Colocación de las puertas para facilitar los controles Collocazione delle porte per facilitare i controlli
8	High serviceability level Haut niveau d'accessibilité pour la manutention Alto nivel de accesibilidad para la manutención Alto livello di accessibilità per la manutenzione
9	Large cable entry area for easy installation Grande zone d'entré des câbles pour une installation plus facile Amplia área de entrada cables para una instalación fácil Ampia area di entrata cavi per una facile installazione
10	Galvanized metal steel sheet pre-treated prior to powder coating Tôles en acier galvanisé pré-traitées avant le vernissage à poudre Chapas de acero cincado pre-tratadas antes de la pintura a polvo Lamiere di acciaio zincato pre-trattate prima della verniciatura a polvere

TENAX V series - OPEN VERSION DRAWING
Série TENAX v - DESSIN VERSION SUR SKID
Serie TENAX v - DIBUJO VERSION ABIERTA
Serie TENAX v - DISEGNO VERSIONE APERTA

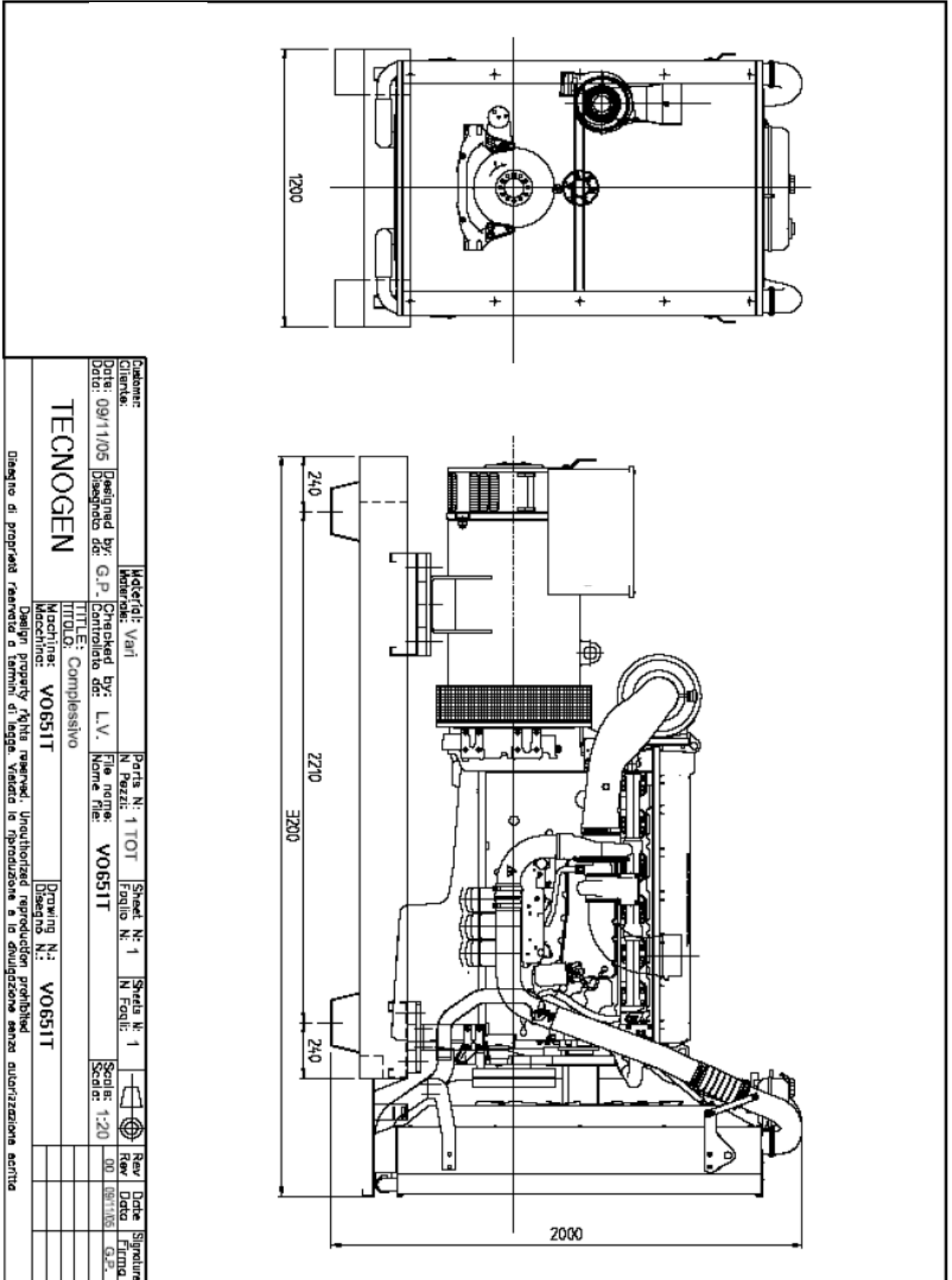

Customer:	Material:	Parti N.:	Sheet N.:	Sheets N.:	Rev	Date	Signature
Client:	Varî	1 TOT	1	1	00	09/11/05	G.P.
Date: 09/11/05	Designed by: G.P.	File name:	FOGLIO N.:	N Fogli:	Rev	Date	Firma
	Disegnata da:	V0651T	V0651T		00	09/11/05	G.P.
	Checked by: L.V.	Nome file:					
	Controllo da:						
TECNOGEN		TITOLO: Complessivo		Drawing N.:		V0651T	
		Macchine: V0651T		Disegno N.:		V0651T	
<p>Disegni di proprietà riservata a termini di legge. Validato la riproduzione e la divulgazione senza autorizzazione scritta</p>							

TENAX V series - SOUND PROOF VERSION DRAWING
Série TENAX v- DESSIN VERSION INSONORIZEE
Serie TENAX v - DIBUJO VERSION INSONORISADA
Serie TENAX v- DISEGNO VERSIONE INSONORIZZATA

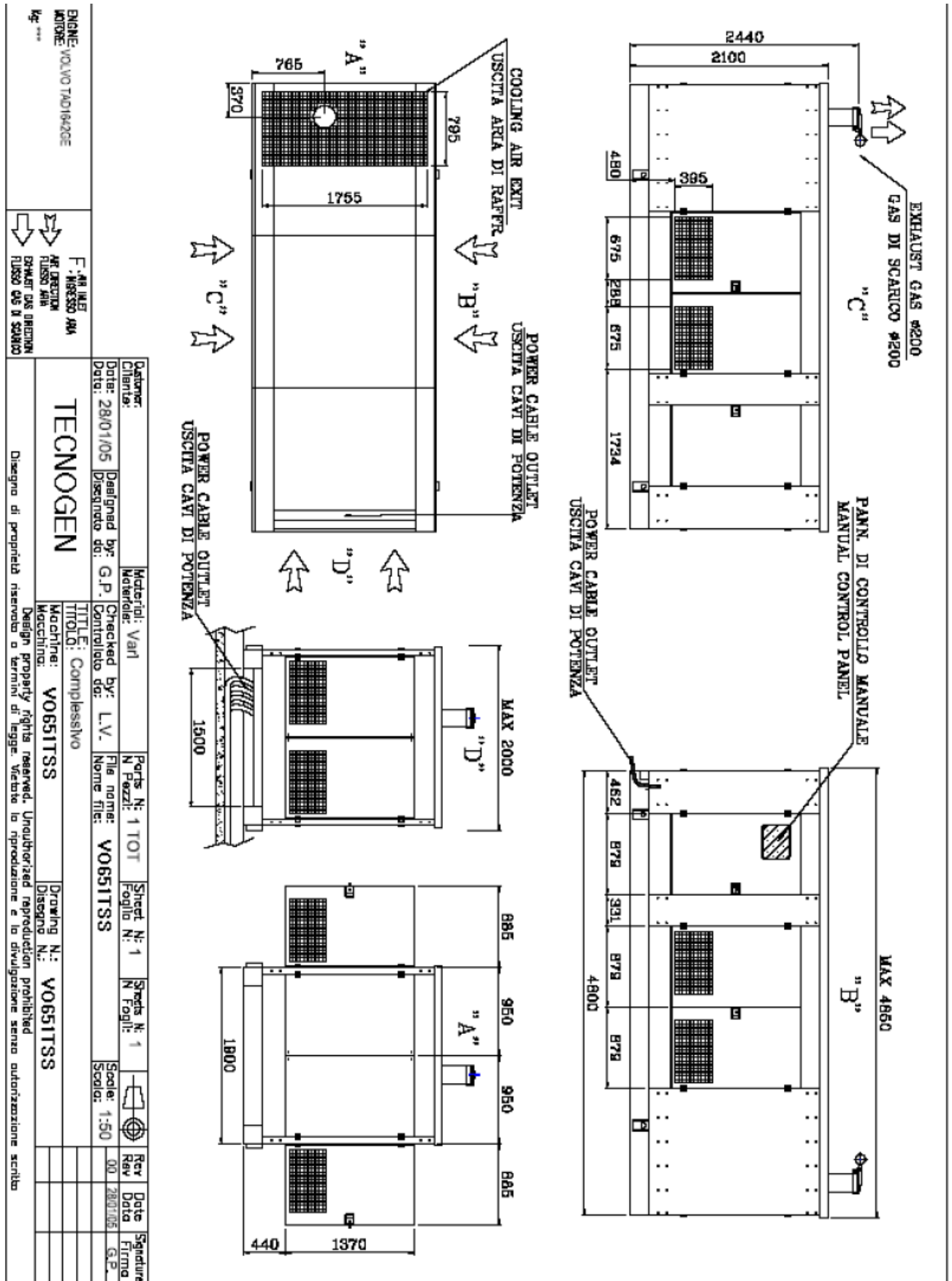

VOLVO PENTA GENSET ENGINE

TAD1642GE

536 kW (729 hp) at 1500 rpm, 585 kW (796 hp) at 1800 rpm, acc. ISO 3046

The TAD1642GE is a powerful, reliable and economical Generating Set Diesel Engine built on the dependable in-line six design.

Durability & low noise

Designed for easiest, fastest and most economical installation. Well-balanced to produce smooth and vibration-free operation with low noise level.

To maintain a controlled working temperature in cylinders and combustion chambers, the engine is equipped with piston cooling. The engine is also fitted with replaceable cylinder liners and valve seats/guides to ensure maximum durability and service life of the engine.

Low exhaust emission

The state of the art, high-tech injection and charging system with low internal losses contributes to excellent combustion and low fuel consumption.

The TAD1642GE complies with EU Stage 2 exhaust emission regulations.

Easy service & maintenance

Easily accessible service and maintenance points contribute to the ease of service of the engine.

Technical description

Engine and block

- Optimized cast iron cylinder block with optimum distribution of forces without the block being unnecessarily heavy.
- Wet, replaceable cylinder liners
- Piston cooling for low piston temperature and reduced ring temperature
- Tapered connecting rods for reduce risk of piston cracking
- Crankshaft induction hardened bearing surfaces and fillets with seven bearings for moderate load on main and high-end bearings
- Case hardened and Nitrocarburized transmission gears for heavy duty operation
- Keystone top compression rings for long service life
- Viscous type crankshaft vibration dampers to withstand single bearing alternator torsional vibrations
- Replaceable valve guides and valve seats
- Over head camshaft and four valves per cylinder

Lubrication system

- Full flow oil cooler
- Full flow disposable spin-on oil filter, for extra high filtration
- The lubricating oil level can be measured during operation
- Gear type lubricating oil pump, gear driven by the transmission

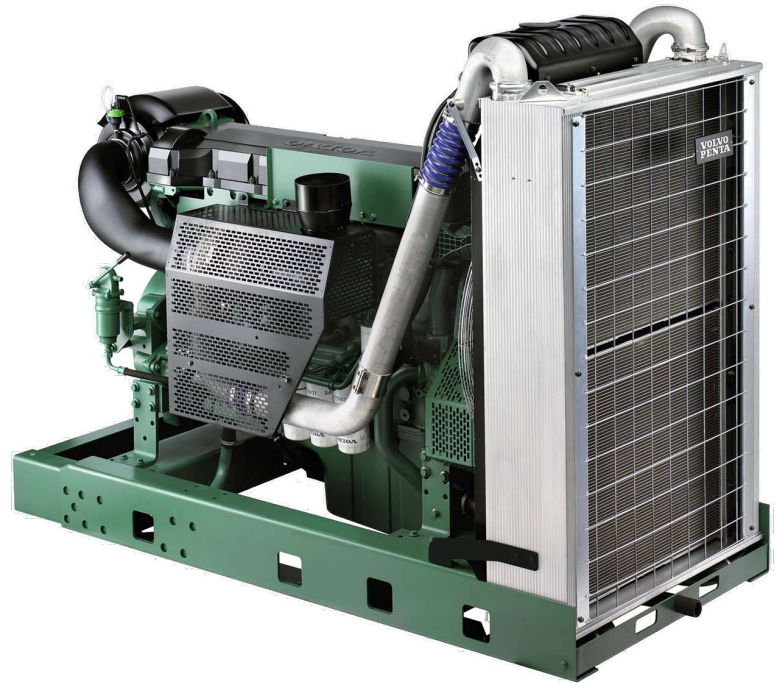

Features

- Maintained performance, air temp 40°C
- Cooling system (55°C)
- Fully electronic with Volvo Penta EMS 2
- Dual frequency switch (between 1500 rpm and 1800 rpm)
- High power density
- Emission compliant
- Low noise levels
- Gen Pac configuration

Fuel system

- Non-return fuel valve
- Electronic unit injectors
- Fuel prefilter with water separator and water-in-fuel indicator / alarm
- Gear driven low-pressure fuel pump
- Fine fuel filter with manual feed pump and fuel pressure switch
- Fuel shut-off valve, electrically operated

Cooling system

- Efficient cooling with accurate coolant control through a water distribution duct in the cylinder block. Reliable sleeve thermostat with minimum pressure drop
- Belt driven, maintenance-free coolant pump with high degree of efficiency
- Coolant filter as standard

Turbo charger

- Efficient and reliable turbo charger
- Extra oil filter for the turbo charger

Electrical system

- Engine Management System 2 (EMS 2), an electronically controlled processing system which optimizes engine performance. It also includes advanced facilities for diagnostics and fault tracing
- The instruments and controls connect to the engine via the CAN SAE J1939 interface, either through the Control Interface Unit (CIU) or the Digital Control Unit (DCU). The CIU converts the digital CAN bus signal to an analog signal, making it possible to connect a variety of instruments. The DCU is a control panel with display, engine control, monitoring, alarm, parameter setting and diagnostic functions. The DCU also presents error codes in clear text.
- Sensors for oil pressure, oil temp, boost pressure, boost temp, coolant temp, fuel temp, water in fuel, fuel pressure and two speed sensors.

**VOLVO
PENTA**

TAD1642GE

Technical Data

General

Engine designation	TAD1642GE	
No. of cylinders and configuration.....	in-line 6	
Method of operation	4-stroke	
Bore, mm (in.).....	144 (5.67)	
Stroke, mm (in.).....	165 (6.50)	
Displacement, l (in ³).....	16.12 (983.7)	
Compression ratio.....	16.5:1	
Dry weight, kg (lb).....	1480 (3263)	
Dry weight with Gen Pac, kg (lb).....	1910 (4211)	
Wet weight, kg (lb).....	1550 (3417)	
Wet weight with Gen Pac, kg (lb).....	2020 (4453)	

Performance	1500 rpm	1800 rpm
with fan, kW (hp) at:		
Prime Power	485 (660)	532 (724)
Max Standby Power	536 (729)	585 (796)

Lubrication system	1500 rpm	1800 rpm
Oil consumption, liter/h (US gal/h) at:		
Prime Power	0.10 (0.026)	0.11 (0.029)
Max Standby Power	0.11 (0.029)	0.12 (0.032)
Oil system capacity incl filters, liter	48	

Fuel system	1500 rpm	1800 rpm
Specific fuel consumption at:		
Prime Power, g/kWh (lb/hph)		
25 %	213 (0.345)	227 (0.367)
50 %	198 (0.321)	204 (0.330)
75 %	197 (0.320)	202 (0.328)
100 %	201 (0.326)	209 (0.339)
Max Standby Power, g/kWh (lb/hph)		
25 %	208 (0.337)	220 (0.357)
50 %	197 (0.320)	203 (0.329)
75 %	200 (0.323)	204 (0.330)
100 %	204 (0.330)	212 (0.343)

Intake and exhaust system	1500 rpm	1800 rpm
Air consumption, m ³ /min (cfm) at:		
Prime Power	38.0 (1342)	45.4 (1603)
Max Standby Power	40.6 (1434)	46.6 (1646)
Max allowable air intake restriction, kPa (In wc)	5 (20.1)	5 (20.1)
Heat rejection to exhaust, kW (BTU/min) at:		
Prime Power	375 (21326)	439 (24965)
Max Standby Power	426 (24226)	500 (28435)
Exhaust gas temperature after turbine, °C (°F) at:		
Prime Power	471 (880)	468 (874)
Max Standby Power	494 (920)	512 (954)
Max allowable back-pressure in exhaust line, kPa (In wc)	10 (40.2)	10 (40.2)
Exhaust gas flow, m ³ /min (cfm) at:		
Prime power	92.6 (3270)	108.9 (3846)
Max Standby Power	100.7 (3556)	117.6 (4153)

Cooling system	1500 rpm	1800 rpm
Heat rejection radiation from engine, kW (BTU/min) at:		
Prime Power	18 (1024)	20 (1137)
Max Standby Power	20 (1137)	24 (1365)
Heat rejection to coolant kW (BTU/min) at:		
Prime Power	187 (10635)	218 (12397)
Max Standby Power	218 (12397)	248 (14104)
Fan power consumption, kW (hp)	11 (15)	19 (26)

Standard equipment

	Engine	Gen Pac
Engine		
Automatic belt tensioner	•	•
Lift eyelets	•	•
Flywheel		
Flywheel housing with conn. acc. to SAE 1	•	•
Flywheel for 14" flex. plate and flexible coupling	•	•
Vibration dampers	•	•
Engine suspension		
Fixed front suspension	•	•
Lubrication system		
Oil dipstick	•	•
Full-flow oil filter of spin-on type	•	•
By-pass oil filter of spin-on type	•	•
Oil cooler, side mounted	•	•
Low noise oil sump	•	•
Fuel system		
Fuel filters of disposable type	•	•
Electronic unit injectors	•	•
Pre-filter with water separator	•	•
Intake and exhaust system		
Air filter with replaceable paper insert	•	•
Air restriction indicator	•	•
Air cooled exhaust manifold	•	•
Connecting flange for exhaust pipe	•	•
Exhaust flange with v-clamp	•	•
Turbo charger, low right side	•	•
Cooling system		
Radiator incl intercooler	• ¹⁾	•
Gear driven coolant pump	•	•
Fan hub	•	•
Thrust fan	• ¹⁾	•
Fan guard	-	•
Belt guard	-	•
Control system		
Engine Management System (EMS) with CAN-bus interface SAE J1939	•	•
CIU, Control Interface Unit	-	-
Alternator		
Alternator 80A / 24 V	•	•
Starting system		
Starter motor, 7.0kW, 24 V	•	•
Connection facility for extra starter motor	•	•
Instruments and senders		
Temp.- and oil pressure for automatic stop/alarm 103°C	•	•
Other equipment		
Expandable base frame	-	•
Engine Packing		
Plastic wrapping	•	•

¹⁾ must be ordered, see order specification
 - optional equipment or not applicable
 • included in standard specification

Dimensions TAD1642GE

Not for installation

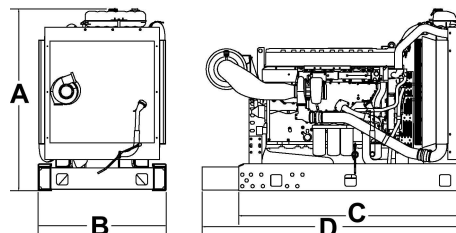

A* = 1587 mm / 62.5 in
 B* = 1120 mm / 44.1 in
 C* = 1976 mm / 77.8 in
 D = 2296 mm / 90.5 in (During transport)
 D = Max 3311 mm / 130.5 in
 * Including radiator and intercooler

Note! Not all models, standard equipment and accessories are available in all countries. All specifications are subject to change without notice. The engine illustrated may not be entirely identical to production standard engines.

Power Standards

The engine performance corresponds to ISO 3046, BS 5514 and DIN 6271. The technical data applies to an engine without cooling fan and operating on a fuel with calorific value of 42.7 MJ/kg (18360 BTU/lb) and a density of 0.84 kg/liter (7.01 lb/US gal), also where this involves a deviation from the standards. Power output guaranteed within 0 to +2% at rated ambient conditions at delivery. Ratings are based on ISO 8528. Engine speed governing in accordance with ISO 3046/IV, class A1 and ISO 8528-5 class G3

Exhaust emissions

The engine complies with EU stage 2 emission legislation according to the Non Road Directive EU 97/68/EEC. The engine also complies with TA-luft -50% exhaust emission regulations.

Rating Guidelines

PRIME POWER rating corresponds to ISO Standard Power for continuous operation. It is applicable for supplying electrical power at variable load for an unlimited number of hours instead of commercially purchased power. A10 % overload capability for governing purpose is available for this rating. MAXIMUM STANDBY POWER rating corresponds to ISO Standard Fuel Stop Power. It is applicable for supplying standby electrical power at variable load in areas with well established electrical networks in the event of normal utility power failure. No overload capability is available for this rating.
 1 hp = 1 kW x 1.36

Information

For more technical data and information, please look in the Generating Set Engines Sales Guide.

VOLVO PENTA

AB Volvo Penta
 SE-405 08 Göteborg, Sweden
 www.volvopenta.com

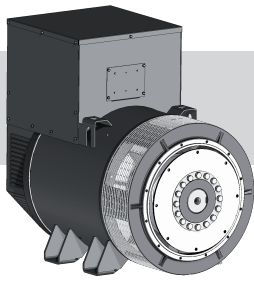

meccalte



ECO 40

MECCALTE spa - Via Roma, 20 - 36051 CREAZZO (VI) ITALIA
 Tel. +39 0444/396111 - Fax +39 0444/396166 - e-mail: info@meccalte.it
 web site: www.meccalte.com

4 POLE

CHARACTERISTICS

INDUSTRIAL RATINGS

ambient 40 °C

Type	kVA - cos φ 0.8 - 3 Phase continuous							Efficiency		
	CL. H (ΔT= 125 °C)				CL. F (ΔT= 105 °C)			η % CL. H (ΔT= 125 °C)		
50 Hz										
Series Star Y	760	800	830		760	800	830			
Parallel Star YY	380	400	415	IP45	380	400	415			
Series Delta Δ	440	460	480	400V	440	460	480	2/4	3/4	4/4
Parallel Delta ΔΔ	220	230	240		220	230	240			
ECO40-1S/4	400	400	400	330	370	370	370	92,9	93,8	93,5
ECO40-2S/4	450	450	450	370	410	410	410	93,2	94	93,7
ECO40-3S/4	500	500	500	410	450	450	450	93,3	94,2	93,9
ECO40-1L/4	550	550	540	450	500	500	490	93,7	94,6	94,2
ECO40-1.5L/4	620	620	620	480	560	560	560	93,7	94,6	94,3
ECO40-2L/4	680	680	680	500	630	630	630	93,8	94,7	94,3
ECO40-VL/4	720	720	710	520	660	660	650	93,9	94,8	94,4

60 Hz	CL. H (ΔT= 125 °C)				CL. F (ΔT= 105 °C)			Efficiency		
								η % CL. H (ΔT= 125 °C)		
Series Star Y	880	920	960		880	920	960			
Parallel Star YY	440	460	480	IP45	440	460	480			
Series Delta Δ	508	530	554	480V	508	530	554	2/4	3/4	4/4
Parallel Delta ΔΔ	254	265	277		254	265	277			
ECO40-1S/4	450	480	480	396	410	440	440	94,4	95,2	95
ECO40-2S/4	510	540	540	444	460	490	490	94,2	95,5	94,7
ECO40-3S/4	580	600	600	492	520	540	540	94,8	95,6	95,2
ECO40-1L/4	630	660	660	540	570	600	600	94,8	95,5	95,2
ECO40-1.5L/4	700	744	744	576	632	672	672	95,3	96,4	95,7
ECO40-2L/4	780	816	816	600	720	756	756	95,5	96,7	95,8
ECO40-VL/4	865	865	865	625	800	800	800	95,8	96,8	96

STANDBY RATINGS

Type	kVA Temp. Rise / Ambient °C			kVA Temp. Rise / Ambient °C		
	50 Hz			60 Hz		
	163° / 27°	150° / 40°	125° / 27°	163° / 27°	150° / 40°	125° / 27°
ECO40-1S/4	437	417	417	525	500	500
ECO40-2S/4	491	468	468	590	563	563
ECO40-3S/4	546	521	521	656	625	625
ECO40-1L/4	601	567	567	722	680	680
ECO40-1.5L/4	670	640	640	805	770	770
ECO40-2L/4	735	700	700	882	840	840
ECO40-VL/4	779	740	740	935	890	890

Type	J (Kgm ²) B3-B14 FORM	Weight (Kg)	Air Volume		Noise dB(A)			
					50 Hz		60 Hz	
			50 Hz (m ³ /min)	60 Hz (m ³ /min)	1m	7m	1m	7m
ECO40-1S/4	5,504	1040	54	64,8	94	82	98	88
ECO40-2S/4	6,240	1118						
ECO40-3S/4	6,852	1171						
ECO40-1L/4	7,356	1324						
ECO40-1.5L/4	8,739	1380						
ECO40-2L/4	9,258	1586						
ECO40-VL/4	9,874	1693						

ACCESSORIES

REGULATOR				PARALLEL DEVICE	THERMAL PROTECTION			HEATERS	MECHANICAL PROTECTION		
DSR	DER-1	SR7/2	UVR6		PTC	BIMET. DEVICE	PT100		IP21	IP23	IP45
<input type="checkbox"/>	<input checked="" type="checkbox"/>	<input type="checkbox"/>	<input type="checkbox"/>	<input checked="" type="checkbox"/>	<input type="checkbox"/>	<input type="checkbox"/>	<input type="checkbox"/>	<input type="checkbox"/>	<input checked="" type="checkbox"/>	<input type="checkbox"/>	<input type="checkbox"/>

● = Standard
 = Optional

Rating



OVERALL DIMENSIONS B3 - B14 FORM

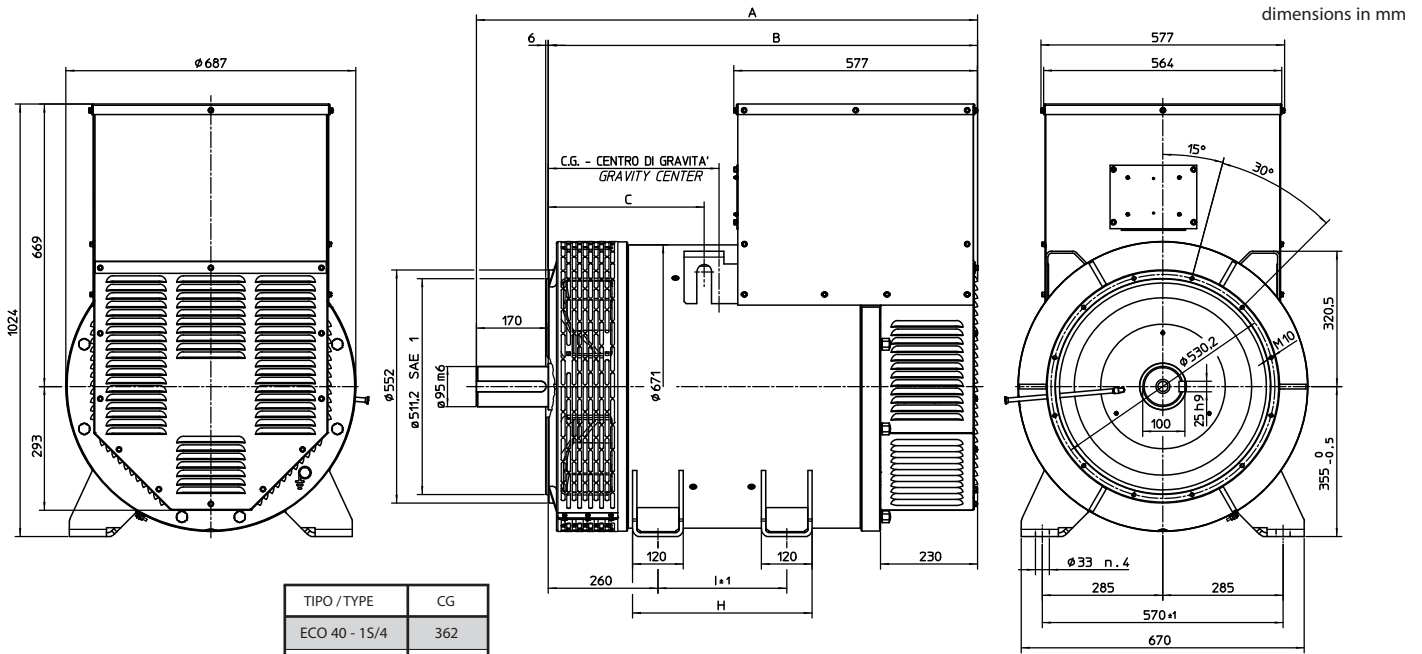

TIPO / TYPE	CG
ECO 40 - 1S/4	362
ECO 40 - 2S/4	372
ECO 40 - 3S/4	442
ECO 40 - 1L/4	537
ECO 40 - 1.5L/4	542
ECO 40 - 2L/4	547
ECO 40 - VL/4	594

TIPO/TYPE/TYP/TYP/TIPO	A	B	C	I	H
ECO 40 S	1187	1017	369,5	305	425
ECO 40 L	1352	1182	534,5	470	590
ECO 40 VL	1452	1282	634,5	470	590

OVERALL DIMENSIONS MD35 FORM

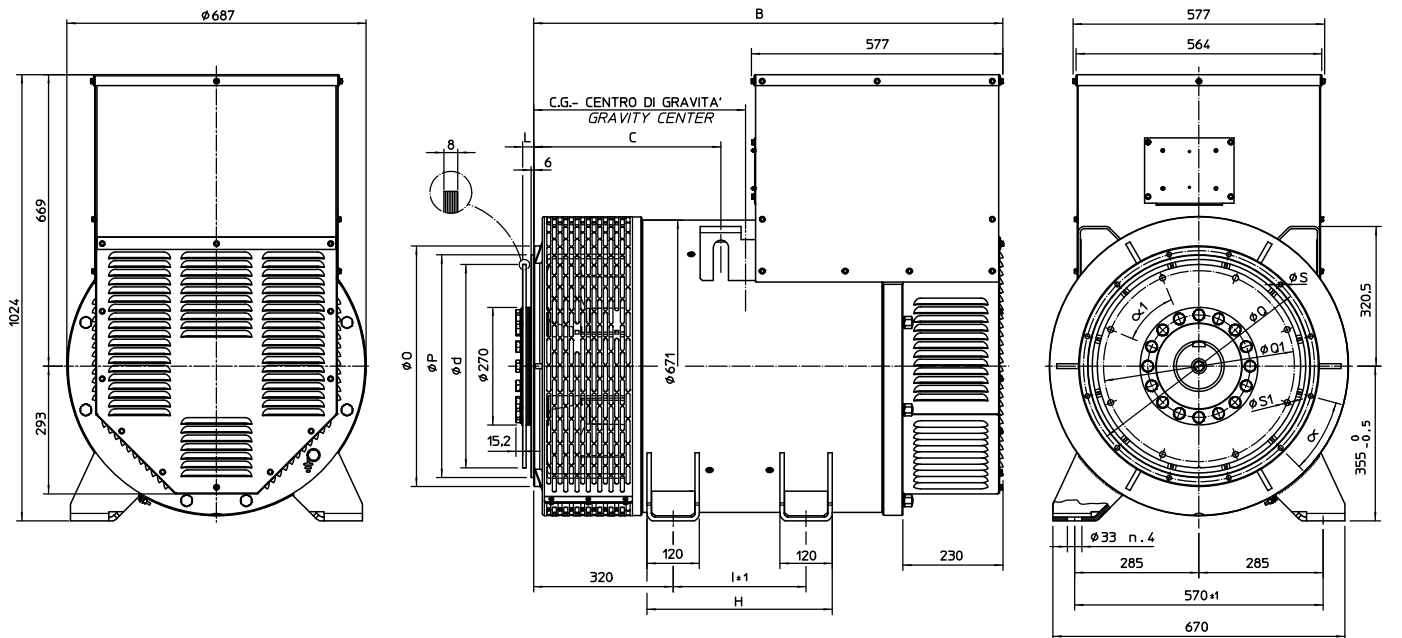

TIPO / TYPE	CG
ECO 40 - 1S/4	422
ECO 40 - 2S/4	432
ECO 40 - 3S/4	442
ECO 40 - 1L/4	597
ECO 40 - 1.5L/4	600
ECO 40 - 2L/4	607
ECO 40 - VL/4	650

SAE N.	FLANGIE FLANGE BRIDE FLANSCH BRIDAS					
	O	P	Q	n. fori	S	α
1	552	511,2	530,2	12	11	30°
1/2	648	584,2	619,1	12	14	30°
0	711	647,7	679,5	16	14	22,5°
00	883	787,4	850,9	16	14	22,5°

SAE N.	GIUNTI A DISCHI DISC COUPLING DISQUE DE MONOPALIER SCHEIBENKUPPLUNG						
	L	d	Q1	n. fori	S1	α 1	
14	25,4	466,72	438,15	8	14	45°	
18	15,7	571,5	542,92	6	17	60°	

TIPO/TYPE/TYP/TYP/TIPO	B	C	I	H
ECO 40 S	1077	429,5	305	425
ECO 40 L	1242	594,5	470	590
ECO 40 VL	1342	604,5	470	590