

**Generator set**  
**Sound-proof type**  
**WCS550S-AU**

**SPECIFICATIONS**

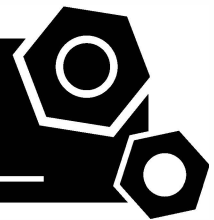

## 1 Standards & Conditions

### Design Standards

The designs and the productions are in conformity with:

- Conformance Européenne (CE)
- ISO8528-5:2005
- AS 3000-2018
- AS 3010-2017

### Environmental Operating Conditions

- Installation place: Outdoors or indoors (well ventilated).
- Ambient temperature: -25°C to 50°C. The coolant heater is needed when the temperature is below 5°C
- Humidity: Less than 80%.
- Altitude: Below one thousand (1000) meters above sea Level.

### Factory Inspection

- Inspection items.
- Protection devices working test.
- Starting ability in normal temperature.
- 50% rated power load moment capability.
- Voltage deviation and speed variation: 0%, 25%, 50%, 75%, 100%, 110% Load.

### Painting Process

- Painting process specifications and colors are based on the manufacturer's standard.
- The customer could also choose the color which the manufacturer offers.

## 2 General Features

- Cummins engine QSX15-G8
- Close coupled to a Stamford alternator HCI544D
- Microprocessor control module PLC-7420
- ABB main circuit breaker: 800A
- Rotate speed governor: Electronic fuel injection governor
- Excitation system: Self excited
- A.V.R model: AS440
- Voltage changeover switch
- Key switch
- Emergency stop switch
- ATS (automatic transfer switch) receptacle

- 2x12V/200AH sealed for life maintenance free battery
- Lockable battery isolator switch
- Powder coated canopy
- 50°C radiator
- Oil pump on the engine
- Steel base frame with fork slots
- Vibration isolators between the engine/alternator and base frame
- Dry type air filter
- Base fuel tank with 16 hours running
- Drain points for fuel tank
- Operation Manual / Specifications

## 3 Equipment Specification

### General technical data

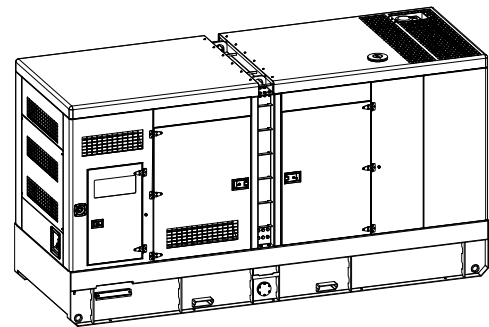

Model.....	WCS550S-AU
Structure type .....	R
Tank capacity.....	1600L
Dry weight.....	6022kg
Sound pressure level @ 7m .....	77.2dBA
Emissions Compliance .....	EU STAGE II
Dimensions L×W×H.....	4662x1623x2566mm
Standby Power .....	550kVA/440kW
Prime Power .....	500kVA/400kW

Voltage	380V	400V	415V	440V	
Ampere	759.6A	721.1A	695.6A	656.1A	
<b>Genset Fuel Consumption</b>					
Frequency/Load	25%	50%	75%	100%	110%
50Hz (L/h)	30.3	54.7	78.7	103	123

## Diesel engine

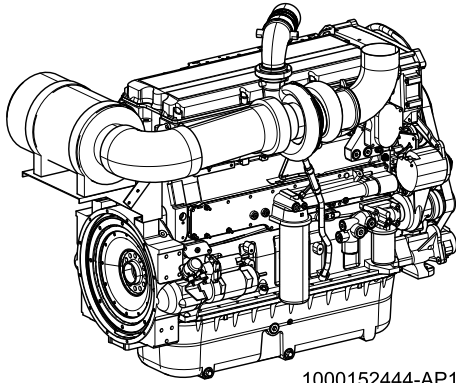

1000152444-AP1-A1

Engine Manufacturer/Brand.....	Cummins
Engine Model.....	QSX15-G8
Dimensions L×W×H.....	2269×1332×1669mm
Dry Weigh (approx.).....	1658kg
Number of Cylinders.....	6
Bore.....	137mm
Stroke.....	169mm
Displacement.....	15L
Compression Ratio.....	17
Type of injection.....	Direct injection
Intake System.....	Turbocharged, air-to-air charge cooled
Intake Resistance.....	6.2kPa
Cooling System.....	Water cooled
Fan.....	Pusher
Battery Voltage.....	24V
Type of Fuel.....	No.2 or ASTM D975
Type of Oil.....	API CH/SE or CCMCH4
Oil Capacity.....	91.0L
Type of Coolant.....	Glycol mixture
Coolant Capacity.....	24.0L
Back Pressure.....	10.1kPa
Standby Power.....	500kW
Prime Power.....	444kW
Fuel Consumption(100%load).....	103L/h

## Alternator

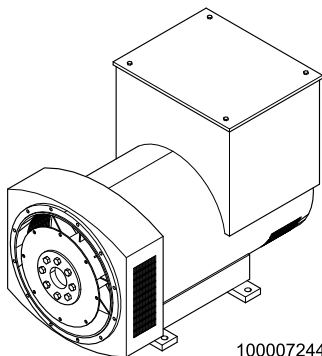

1000072447-AP1-A1

Alternator Manufacturer/Brand.....	Stamford
Alternator Model.....	HCl544D
Exciter.....	Brushless
Cooling Fan.....	Cast alloy aluminum
Windings.....	100% copper
Insulation Class.....	H
Winding Pitch.....	2/3
Terminals.....	12
Drip Proof.....	IP23
Altitude.....	≤1000m
Overspeed.....	2250 rpm
Air Flow.....	1.035m³/s(50HZ), 1.312m³/s(60HZ)
Voltage Regulation.....	±1.0%
Total harmonic TGH / THCat no load < 1.5 % - on load < 5%	
Telephone Interference.....	THF<2%;TIF<50

## PLC-7420 Control System

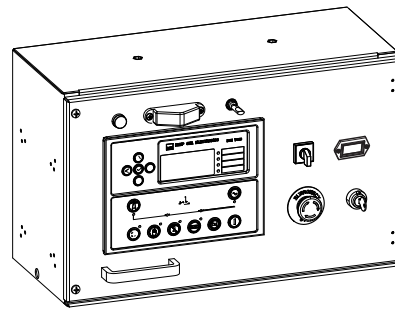

PLC-7420 is an advanced control module based on micro-processor, containing all necessary functions for protection of the genset and the breaker control. It can monitor the mains supply, and automatically start the engine when the mains is abnormal. Accurately measure various operational parameters and display all values and alarms information on the LCD. In addition, the control module can automatically shut down the engine and indicate the engine failure.

- Microprocessor control, with high stability and credibility
- Monitoring and measuring operational parameters of the mains supply and genset
- Indicating operation status, fault conditions, all parameters and alarms
- Multiple protections; multiple parameters display, like pressure, temp. etc.
- Manual, automatic and remote work mode selectable
- Real time clock for time and date display, overall runtime display, 250 log entries
- Overall power output display
- Integral speed/frequency detecting, telling status of start, rated operation, overspeed etc.
- Communication with PC via RS485 OR RS232 interface, using MODBUS protocol

CONTACT US TODAY

1300 885 789 | paul@powergenaustralia.com.au  
powergenaustralia.com.au

**PowerGen**  
AUSTRALIA

AUTHORISED DEALER

## 4 Overall Dimensions

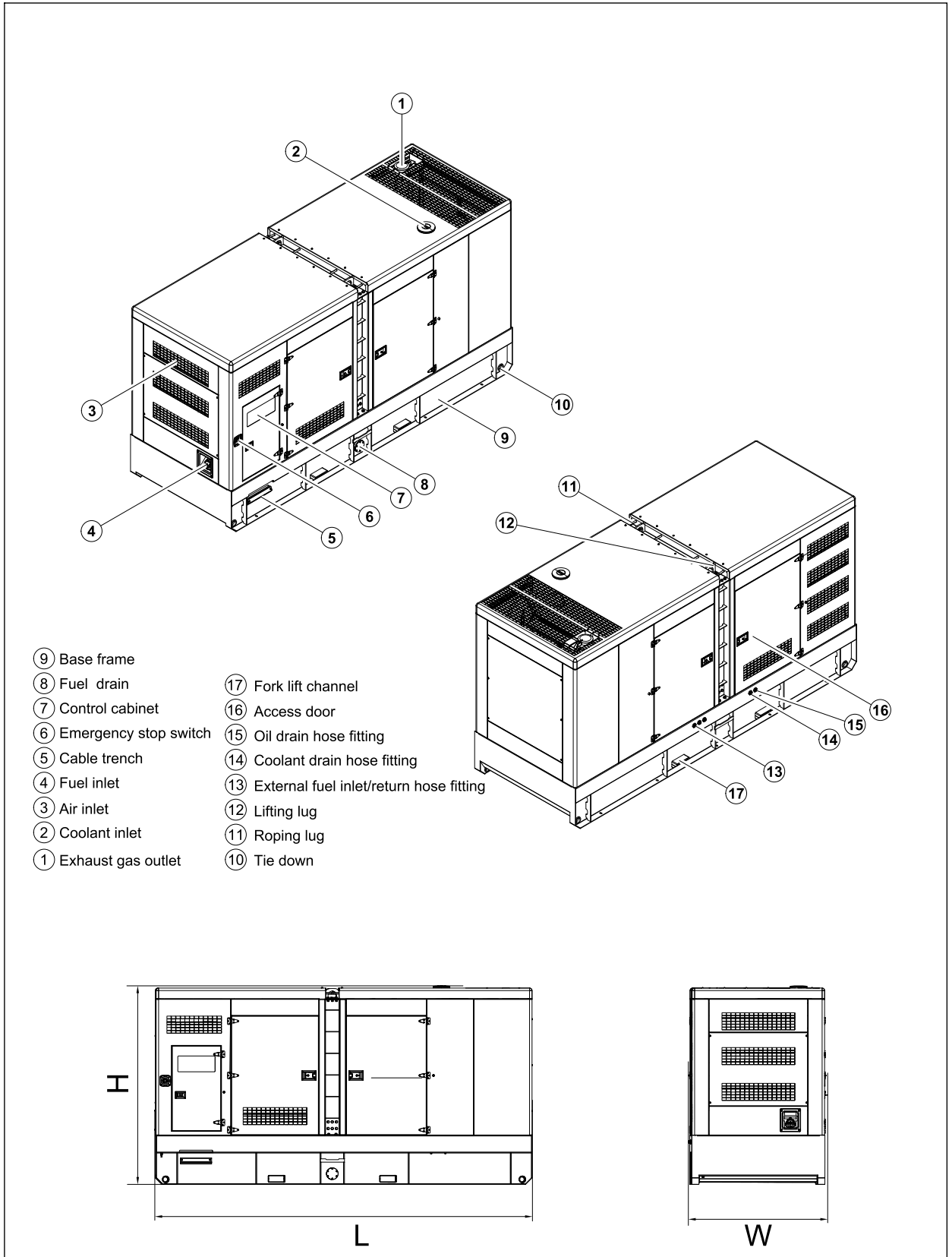

CONTACT US TODAY

1300 885 789 | paul@powergenaustralia.com.au  
powergenaustralia.com.au

**PowerGen**  
— AUSTRALIA —

AUTHORISED DEALER

## 5 Control System

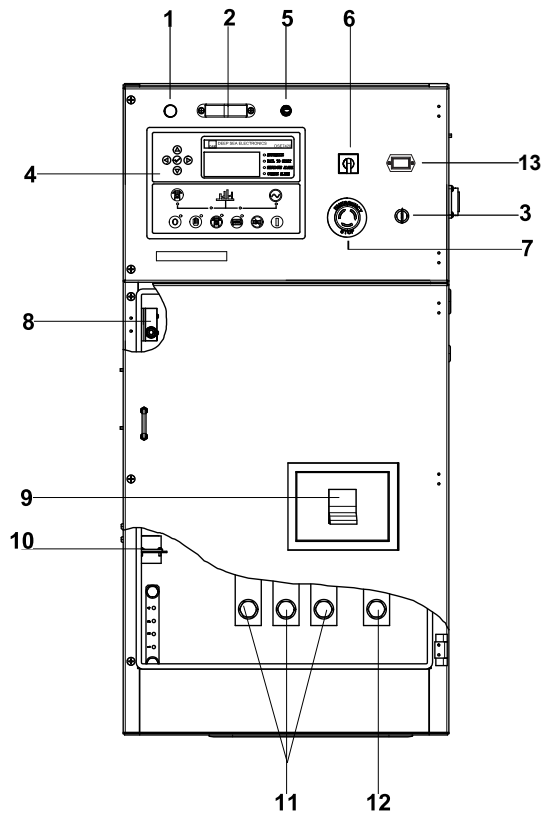

**Control & field wiring cabinet**

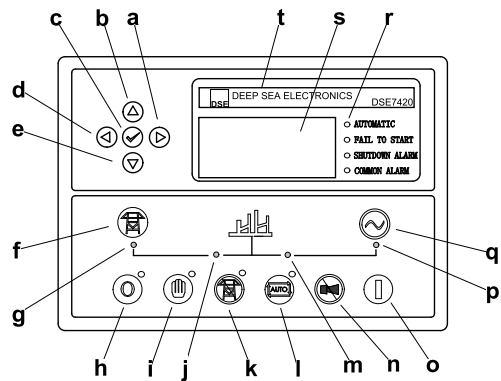

**Control module**

Ref.	Description
1	Charge indicator
2	Control cabinet lamp
3	Key switch
4	Control module
5	Control cabinet lamp switch
6	Mains input changeover switch
7	Emergency stop button
8	Limit switch
9	Main circuit breaker
10	Mains input/remote/AMF communication connector
11	Live wire terminals
12	Neutral wire terminal
13	Time counter

a	Button (next page)
b	Button (increase value / previous item)
c	Button (accept)
d	Button (previous page)
e	Button (decrease value / next item)
f	Button (transfer the load to the mains supply, when in Manual mode only)
g	Mains supply available LED
h	Stop / Reset button
i	Manual button (Manual control mode)
j	Mains supply on load LED
k	Test button (Test mode)
l	Auto button (Auto mode)
m	Genset on load LED
n	Mute/Lamp test button
o	Start button (Manual)
p	Genset available LED
q	Button (transfer the load to the genset, when in Manual mode only)
r	Alarm LED (4 alarm items)
s	LCD display
t	Control module name

CONTACT US TODAY

1300 885 789 | paul@powergenaustralia.com.au  
powergenaustralia.com.au

**PowerGen**  
AUSTRALIA

AUTHORISED DEALER

1000024787-E2-E
10.2020

<http://www.powerlinkworld.com>

*Specification may change without prior notice. For more info., contact Power Link or your local distributors please.*

©2020 POWERLINK

CONTACT US TODAY

1300 885 789 | [paul@powergenaustralia.com.au](mailto:paul@powergenaustralia.com.au)  
[powergenaustralia.com.au](http://powergenaustralia.com.au)

**PowerGen**  
— AUSTRALIA —  
AUTHORISED DEALER