

Mobile light tower

MS1800S-KDC

SPECIFICATIONS

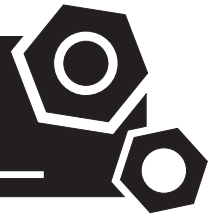

www.powerlinkworld.com

CONTACT US TODAY

1300 885 789 | paul@powergenaustralia.com.au
powergenaustralia.com.au

PowerGen
AUSTRALIA
AUTHORISED DEALER

1 Standards & Conditions

Design Standards

The designs and the productions are in conformity with:

- GB T 1883.1-2005
- JB8891-1999
- GB252-2011
- GB20891-2014
- GB4208-2008
- VSB 1 Rev 4 June 1999
- AS3000: 2018
- AS3010: 2017

Design Conditions

- Installation place: outdoors.
- Ambient temperature: -15°C to 50°C. The coolant heater is needed when the temperature is below 0°C
- Humidity: Less than 90%.
- Altitude: Less than one thousand (1000) meters above sea Level.

Painting Process

- Painting process specifications and colors are based on the manufacturer's standard.
- The customer could also choose the color which the manufacturer offers.

2 General Features

- Kubota engine Z482-E4B-ACP-1
- DC/VF alternator PMG-DC-18-3
- Microprocessor control module PLC-805
- Governor type : Electronic control
- Six masts with manual rotation 359°
- 4x450W diffuse LED
- 1x12V/70AH sealed for life maintenance free battery(supply for engine)
- Emergency stop switch
- DC input socket for charging battery
- Lockable battery isolator switch
- Powder coated canopy
- Vibration isolators between the engine/alternator and base frame
- Dry type air cleaner
- Fuel tank(138 running hours under full load)
- Fuel drain outlet
- Easy maintenance (easy to replace the current rectifier etc.)
- Operation Manual / Specifications

3 Equipment Specification

Mode	MS1800S-KDC
Light type.....	Soft light
Luminous flux(Max)lm.....	151950
Light intensity(Max)cd.....	159843
Tank capacity.....	90L
Wet weigh	1020 kg
Dry weigh	970 kg
Total lighting wattage.....	4x450W
Tire size	175/R13 LT *2
Dimensions (Fully retracted).....	2446x1450x2276mm
Dimensions (Fully extended).....	2446x2562x6000mm
Maximun towing speed.....	80km/h
Maximun wind speed rating.....	102km/h
Sound pressure level @7m	53dB(A)
Fully extended/retracted time	8/10s
Hydraulic oil type	L-HM46
Hydraulic oil tank capacity	5L
Rated load output	3.0kW
Voltage/Ampere	DC 48V/62.5A

Light Tower Fuel Consumption		
Number of running lamp	3xLamps	6xLamps
Fuel Consumption(L/h)	0.37	0.65

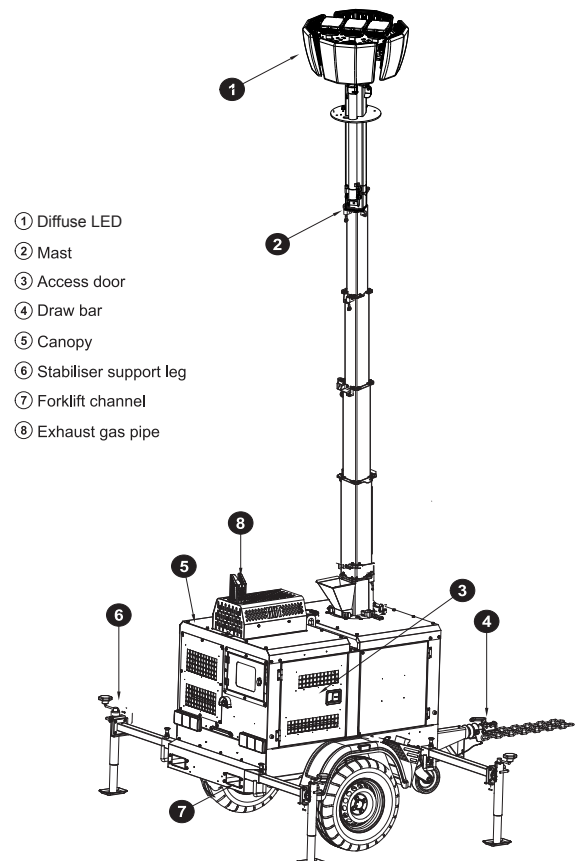

Engine

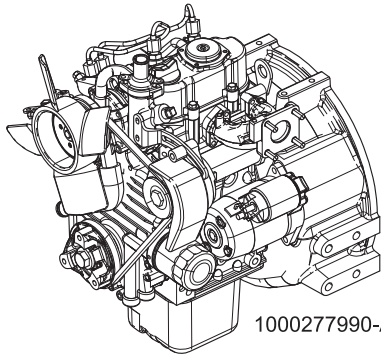

1000277990-AP1-A1

Engine Manufacturer/Brand.....	KUBOTA
Engine Model.....	Z482-E4B-ACP-1
Dimensions LxWxH.....	487.9x412x564.2mm
Dry Weigh (approx.)	80Kg
Number of Cylinders.....	2
Bore.....	67mm
Stroke.....	68mm
Displacement.....	0.479L
Compression Ratio.....	23.5
Type of Injection.....	Spherical Type (E-TVCS)
Intake System.....	Natural aspirated
Intake Resistance.....	≤2.45kPa
Cooling System	Water cooled
Fan	Pusher
Battery Voltage	12V
Type of Fuel.....	No.2-D (ASTMD975)
Type of Oil	API -CH
Oil Capacity	2.5L
Type of Coolant	Glycol mixture
Back Pressure.....	9.33kPa
Speed	1800rpm
Prime Power	4.6kW

Alternator

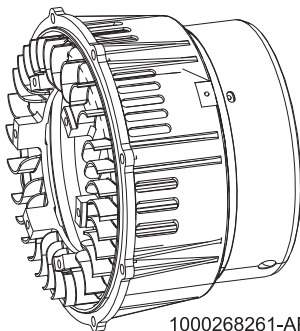

1000268261-AP1-A1

Alternator Manufacturer/Brand.....	POWERLINK
------------------------------------	-----------

Alternator Model	PMG-DC-18-3
Stator Pole Number	30
Speed	1800rpm
Voltage(DC).....	48V
Altitude.....	≤1000m

PLC-805 Control System

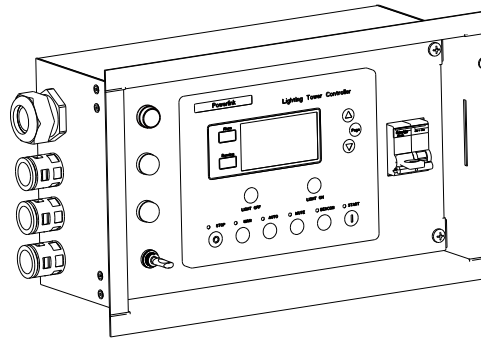

PLC-805 is an advanced control module based on microprocessor, apply to AC/DC light tower. The controller is equipped with a powerful graphic display showing icons, symbols and bar graphs for intuitive operation. Accurately measure various operational parameters and display all values and alarms information on the LCD.

- Microprocessor control, with high stability and credibility
- Monitoring and measuring operational parameters of light tower
- Indicating operation status, fault conditions, all parameters and alarms
- Manual, automatic and remote work mode selectable
- Multiple protections; multiple parameters display, like pressure, temp. etc.
- Overall power output display
- Real time clock for time and date display, overall runtime display, 99 log entries
- Communication with PC via RS485 interface, using MODBUS protocol

CONTACT US TODAY

1300 885 789 | paul@powergenaustralia.com.au
powergenaustralia.com.au

PowerGen
AUSTRALIA
AUTHORISED DEALER

4 Luminaire

Luminaire Data:

Item	Description
Rated power	1800W
Operating voltage	DC 48V
input Current	12*3.13A=37.56A
Diffuser	Polycarbonate
Weather resistance	kLy 300
Flammability	V2
Impact Strength	IK10
Protection standard	IP67
Operating temprature	-30C ~+50C
Luminous Flux	198000-234000LM
Measurement	ø1052mm*512mm
WEIGHT(kg)	≈48.5KG+5.5KG+32.5KG=47KG

Luminous emittance 1:

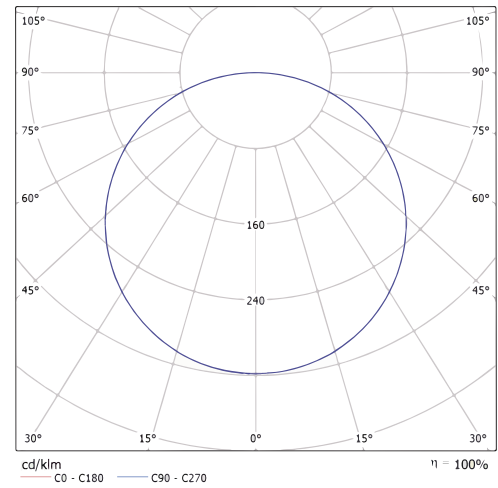

Due to missing symmetry properties, no UGR table can be displayed for this luminaire.

Out-line:

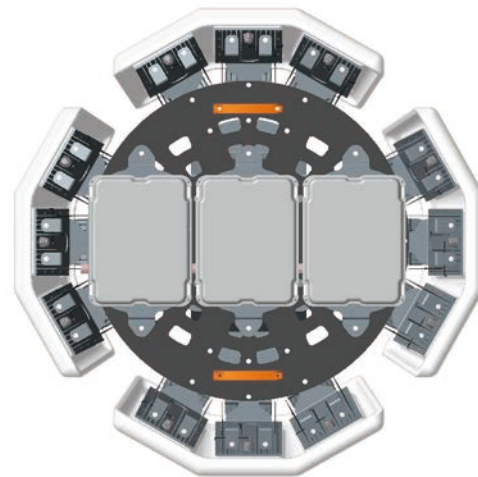
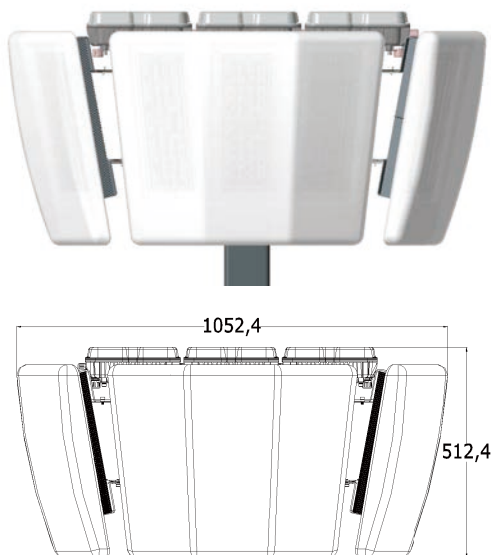

CONTACT US TODAY

1300 885 789 | paul@powergenaustralia.com.au
powergenaustralia.com.au

PowerGen
AUSTRALIA
AUTHORISED DEALER

5 Overall Dimension

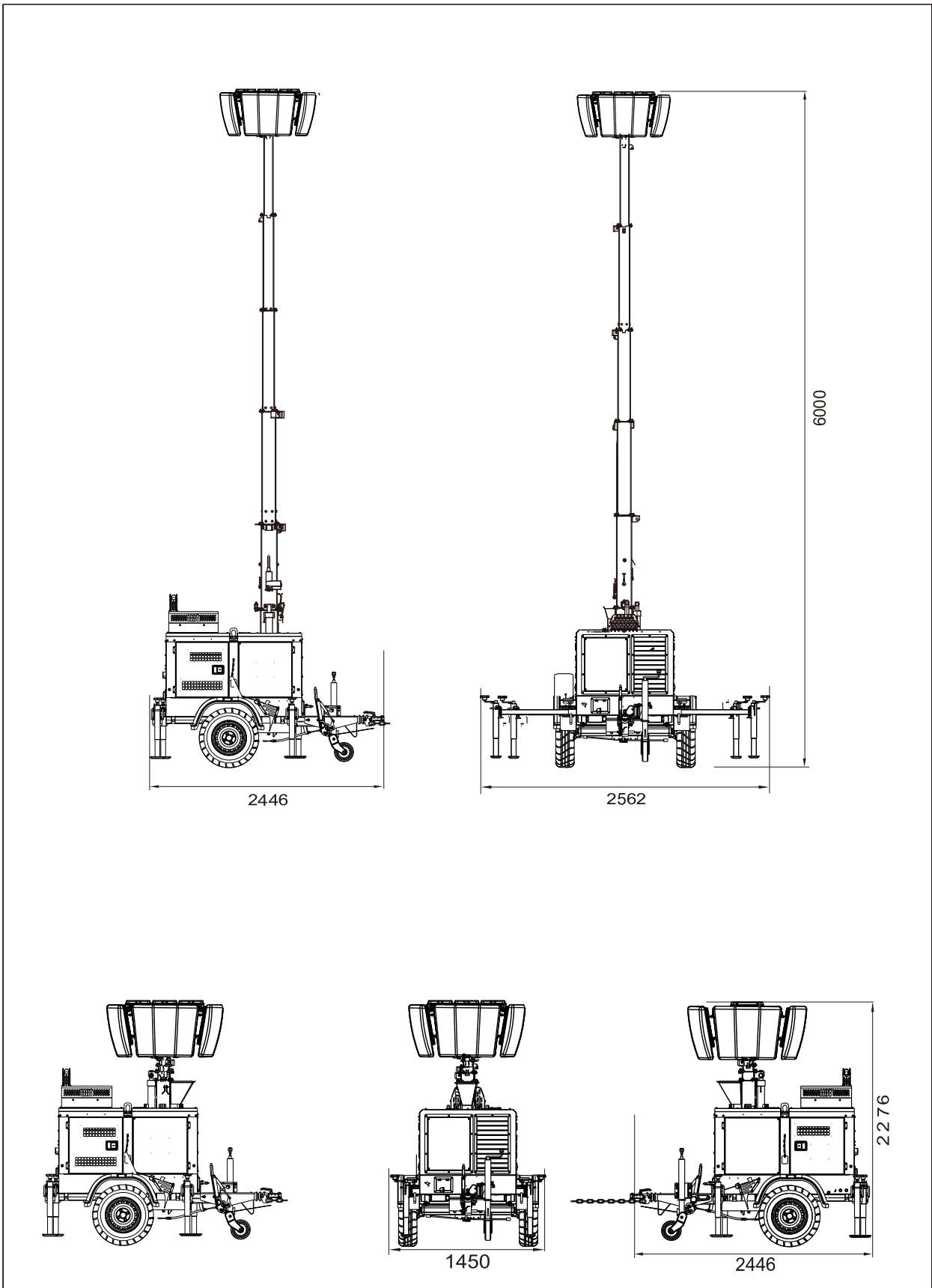

CONTACT US TODAY

1300 885 789 | paul@powergenaustralia.com.au
powergenaustralia.com.au

PowerGen
AUSTRALIA
AUTHORISED DEALER

6 Control System

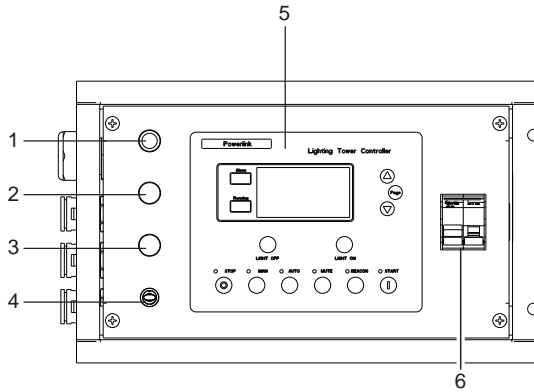

Ref.	Description
1	Alertor
2	Confirm switch
3	Balance indicator of light tower
4	Mast up/down switch
5	Control module
6	Main circuit breaker

Switch cabinet

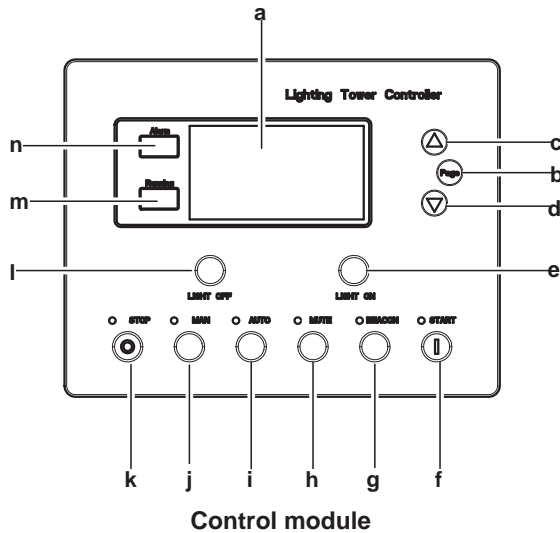

Ref.	Description
a	Main status display
b	Cyclic selection of the display mode (MEASUREMENT->ADJUSTEMENT)
c	Select the set point, select the screen or increase set point value
d	Select the set point, select the screen or decrease set point value
e	Turn on a light each press in manual mode
f	Start of the engine in manual mode
g	Open/close button of Annunciator
h	Deactivates the horn
i	Auto mode
j	Manual mode
k	Stop of the engine/Alarm reset button
l	Turn off a light each press in manual mode
m	Running indicator
n	Alarm indicator

1000271050-IT1-D4

CONTACT US TODAY

1300 885 789 | paul@powergenaustralia.com.au
powergenaustralia.com.au

PowerGen
AUSTRALIA
AUTHORISED DEALER

1000029345-B2-E
02.2019

<http://www.powerlinkworld.com>

Specification may change without prior notice. For more info., contact Power Link or your local distributors please.

©2018 POWERLINK

CONTACT US TODAY

1300 885 789 | paul@powergenaustralia.com.au
powergenaustralia.com.au

PowerGen
— AUSTRALIA —
AUTHORISED DEALER