

Mobile light tower

MS2000-KDC

SPECIFICATIONS

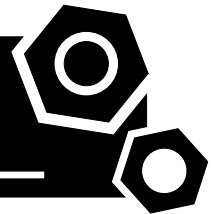

www.powerlinkworld.com

CONTACT US TODAY

1300 885 789 | pau@powergenaustralia.com.au
powergenaustralia.com.au

PowerGen
— AUSTRALIA —
AUTHORISED DEALER

Mobile Light Tower MS2000-KDC, Tier 4F



1 Standards & Conditions

Design Standards

The designs and the productions are in conformity with:

- GB T 1883.1-2005
- JB8891-1999
- GB252-2011
- GB20891-2014
- GB4208-2008
- VSB 1 Rev 4 June 1999
- AS3000: 2018
- AS3010: 2017

Design Conditions

- Installation place: outdoors.
- Ambient temperature: -15°C to 50°C. The coolant heater is needed when the temperature is below 0°C
- Humidity: Less than 90%.
- Altitude: Less than one thousand (1000) meters above sea Level.

Painting Process

- Painting process specifications and colors are based on the manufacturer's standard.
- The customer could also choose the color which the manufacturer offers.

2 General Features

- Kubota engine Z482-E4B-GB
- DC/VF alternator PMG-DC-18-3
- Microprocessor control module PLC-805
- Governor type : Electronic control
- Nine masts with hydraulic extension and manual rotation
- Hydraulic power unit
- Hydraulic cylinder with explosion-proof valve
- 4x500W metal LED lamps
- 1x12V/70AH sealed for life maintenance free battery(supply for engine)
- Emergency stop switch
- DC input socket for charging battery
- Lockable battery isolator switch
- Powder coated canopy
- Vibration isolators between the engine/alternator and base frame
- Axle of leaf spring type
- Dry type air cleaner
- Fuel tank(118 running hours under full load)
- Fuel drain outlet
- Operation Manual / Specification

3 Equipment Specification

Model.....	MS2000-KDC
Light type.....	LED
Luminous flux(Max)lm.....	202600
Light intensity(Max)cd.....	213125
Tank capacity.....	90L
Wet weigh.....	1284kg
Dry weigh.....	1194kg
Total lighting wattage.....	4x500W
Tire size.....	245/75 R16
Dimensions (Fully retracted).....	2222x1598x2417mm
Dimensions (Fully extended).....	2906x2562x9000mm
Tilting Angle of Light Fixture rotation.....	90°
Maximun towing speed.....	80km/h
Maximun wind speed rating.....	102km/h
Sound pressure level @7m.....	53dB(A)
Fully extended/retracted time.....	12/15s
Hydraulic oil type.....	L-HM46
Hydraulic oil tank capacity.....	5L
Rated load output.....	3.0kW
Voltage/Ampere.....	DC 48V/62.5A

Light Tower Fuel Consumption		
Number of running lamp	2xLamps	4xLamps
Fuel Consumption(L/h)	0.48	0.76

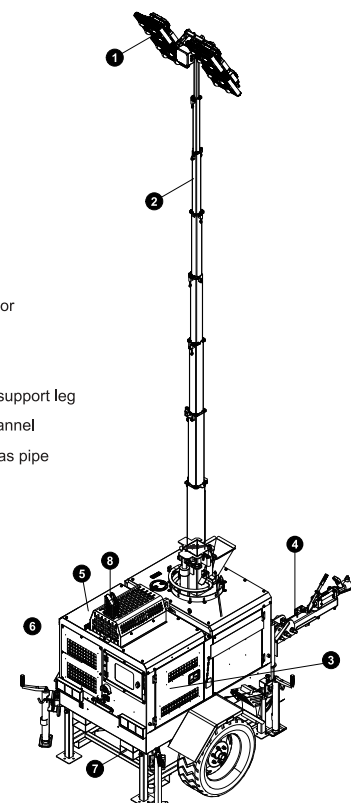

Engine

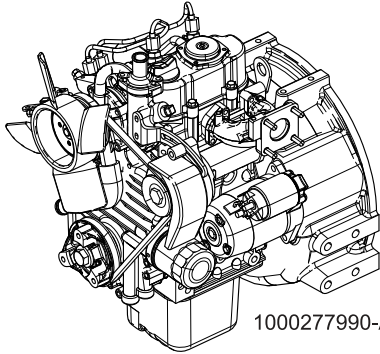

1000277990-AP1-A1

Engine Manufacturer/Brand.....	KUBOTA
Engine Model.....	Z482-E4B-GB
Dimensions L×W×H.....	487.9×412×564.2mm
Dry Weigh (approx.).....	80kg
Number of Cylinders.....	2
Bore.....	67mm
Stroke.....	68mm
Displacement.....	0.479L
Compression Ratio.....	23.5
Type of Injection.....	Spherical Type (E-TVCS)
Intake System.....	Natural aspirated
Intake Resistance.....	≤2.45kPa
Cooling System.....	Water cooled
Fan.....	Pusher
Battery Voltage.....	12V
Type of Fuel.....	No.2-D (ASTMD975)
Type of Oil.....	API -CH
Oil Capacity.....	2.5L
Type of Coolant.....	Glycol mixture
Back Pressure.....	9.33kPa
Speed.....	1800rpm
Prime Power.....	4.6kW

Alternator

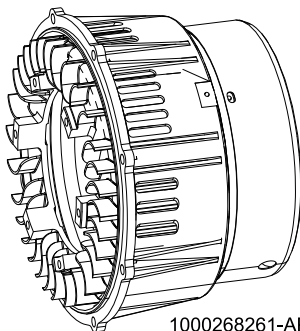

1000268261-AP1-A1

Alternator Manufacturer/Brand.....	POWERLINK
------------------------------------	-----------

Alternator Model.....	PMG-DC-18-3
Stator Pole Number.....	30
Speed.....	1800rpm
Voltage(DC).....	48V
Altitude.....	≤1000m

PLC-805 Control System

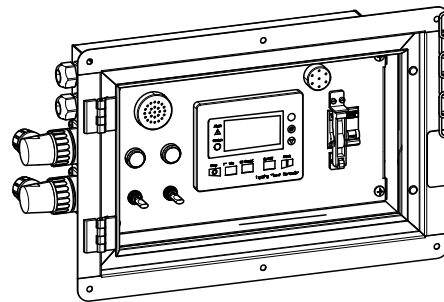

PLC-805 is an advanced control module based on microprocessor, apply to AC/DC light tower. The controller is equipped with a powerful graphic display showing icons, symbols and bar graphs for intuitive operation. Accurately measure various operational parameters and display all values and alarms information on the LCD.

- Microprocessor control, with high stability and credibility
- Monitoring and measuring operational parameters of light tower
- Indicating operation status, fault conditions, all parameters and alarms
- Manual, automatic and remote work mode selectable
- Multiple protections; multiple parameters display, like pressure, temp. etc.
- Overall power output display
- Real time clock for time and date display, overall runtime display, 99 log entries
- Communication with PC via RS485 interface, using MODBUS protocol

CONTACT US TODAY

1300 885 789 | psu@powergenaustralia.com.au
powergenaustralia.com.au

PowerGen
— AUSTRALIA —

AUTHORISED DEALER

4 Luminaire

Luminaire Data:

Item	Description
Rated power	500W
Rated luminous flux	54661.8 lm
Luminaire efficiency	100%
Upper luminous flux ratio	1%
Center light intensity	60740.43 cd
Peak light intensity position	H0 V5
Luminous flux of lamps and lanterns	54661.8 lm
Lower luminous flux ratio	99%
Lamp luminous efficiency rating	110.59
Peak light intensity	60892.13 cd

Luminous emittance 1:

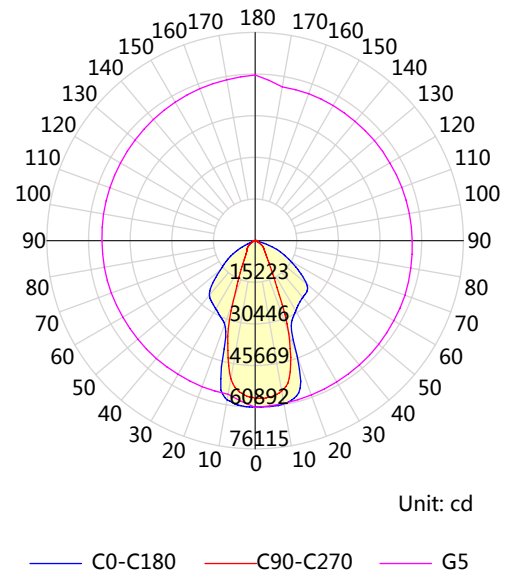

Out-line:

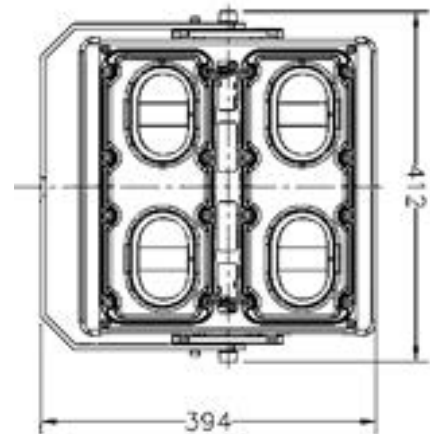
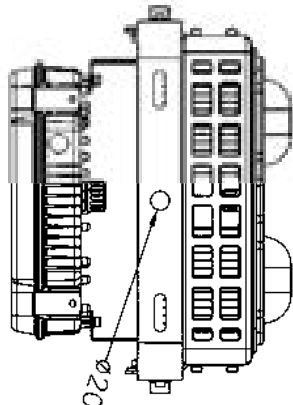
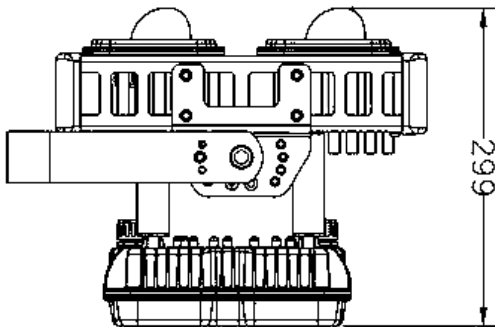

CONTACT US TODAY

1300 885 789 | psu@powergenaustralia.com.au
powergenaustralia.com.au

PowerGen
 AUSTRALIA
 AUTHORISED DEALER

5 Overall Dimension

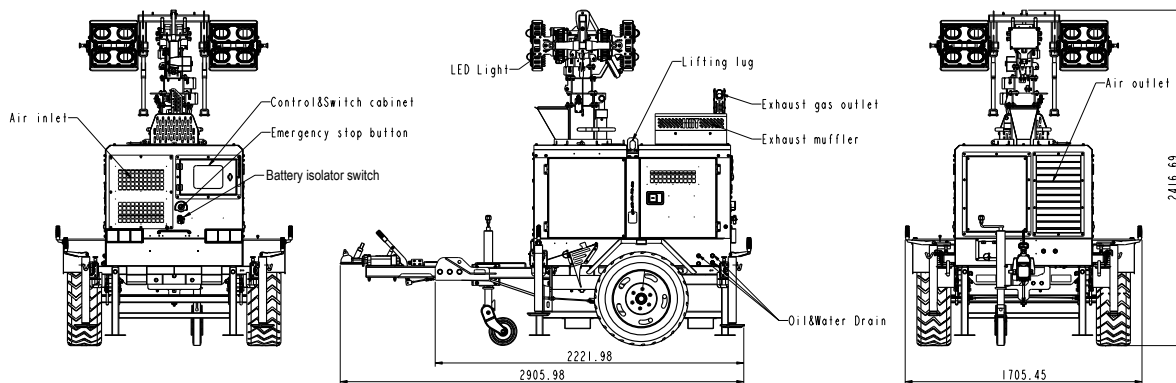
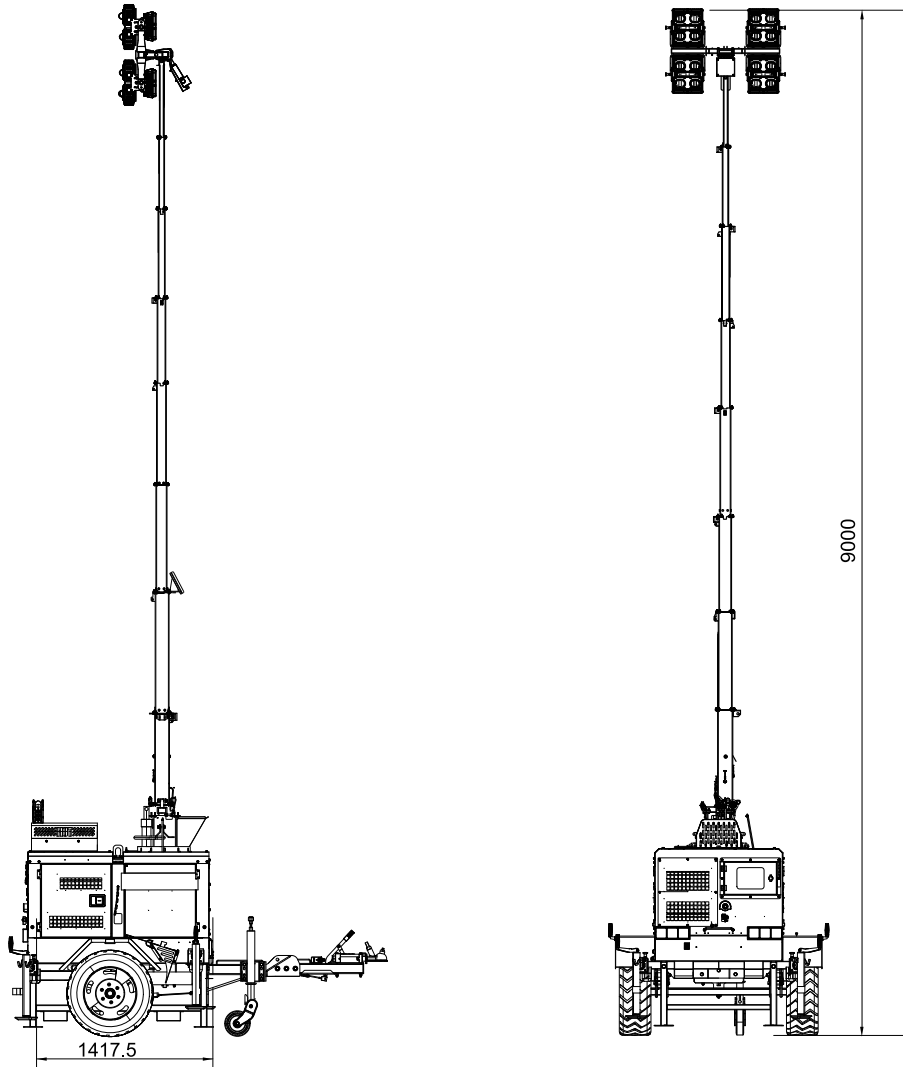

CONTACT US TODAY

1300 885 789 | psu@powergenaustralia.com.au
powergenaustralia.com.au

PowerGen
 AUSTRALIA
 AUTHORISED DEALER

6 Control System

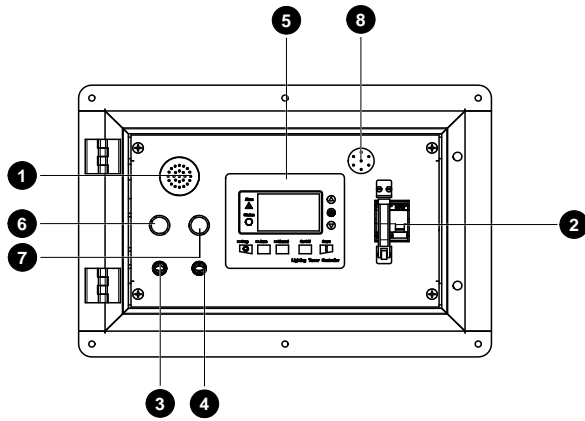

Control cabinet

Ref.	Description
1	Alertor
2	Main circuit breaker
3	Mast up/down switch
4	Lamp tilting switch
5	Control module
6	Confirm switch
7	Balance indicator of light tower
8	Buzzer

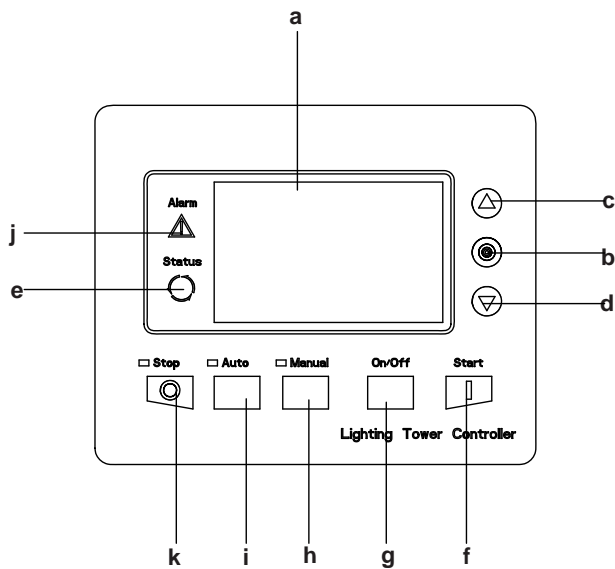

Control module

Ref.	Description
a	Main status display
b	Cyclic selection of the display mode (MEASUREMENT->ADJUSTEMENT)
c	Select the set point, select the screen or increase set point value
d	Select the set point, select the screen or decrease set point value
e	Status Indicator
f	Start of the engine in maunal mode
g	Light On/Off
h	Maunal mode
i	Auto mode
j	Alarm indicator
k	Stop of the engine/Alram reset button

1000034710-A1-E
06.2021

<http://www.powerlinkworld.com>

Specification may change without prior notice. For more info., contact Power Link or your local distributors please.

©2021 POWERLINK

CONTACT US TODAY

1300 885 789 | psu@powergenaustralia.com.au
powergenaustralia.com.au

PowerGen
— AUSTRALIA —
AUTHORISED DEALER