

Generator set
Sound-proof type
B375SE3-AU

SPECIFICATIONS

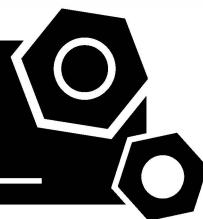

EB series B375SE3-AU, STAGE III

50 Hz @ 1500rpm, 3-phase/5-wiring



1 Standards & Conditions

Design Standards

The designs and the productions are in conformity with:

- Conformance Européenne (CE)
- ISO8528-5:2005
- AS 3000-2018
- AS 3010-2017

Environmental Operating Conditions

- Installation place: Outdoors or indoors (well ventilated).
- Ambient temperature: -25°C to 45°C. The coolant heater is needed when the temperature is below 5°C
- Humidity: Less than 90%.
- Altitude: Below one thousand (1000) meters above sea level.

Factory Inspection

- Inspection items.
- Protection devices working test.
- Starting ability in normal temperature.
- 50% rated power load moment capability.
- Voltage deviation and speed variation: 0%, 25%, 50%, 75%, 100%, 110% Load.

Painting Process

- Painting process specifications and colors are based on the manufacturer's standard.
- The customer could also choose the color which the manufacturer offers.

2 General Features

- Baudouin engine 6M21G2D3/5
- Close coupled to Leroy Somer alternator LSA47.2S4
- Microprocessor control module PLC-7420
- ABB main circuit breaker: 630A, 4P
- Rotate speed governor: ECU
- Excitation System: Self Excited, SHUNT
- A.V.R. Model: R250
- Key switch
- Emergency stop switch
- ATS (automatic transfer switch) receptacle
- Remote run connector
- 2x12V/120AH sealed for life maintenance free battery

- Lockable battery isolator switch
- Powder coated canopy
- 50°C radiator
- Oil pump on the engine
- Non-returning valve for fuel inlet hose of the engine
- Steel base frame with forkslots
- Vibration isolators between the engine/alternator and base frame
- Dry type air filter
- Base fuel tank with 20 hours running
- Drain points for fuel tank
- Breather valve for fuel tank
- Operator's Manual / Specifications

3 Equipment Specification

General technical data

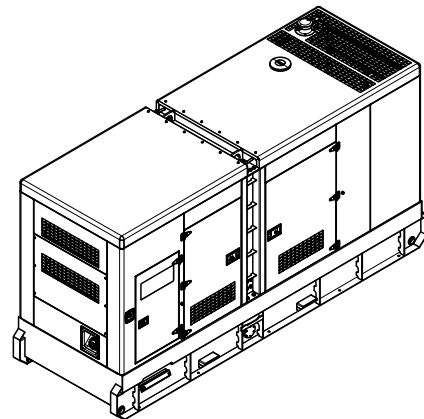

Model.....	B375SE3-AU
Structure type	R
Tank capacity.....	1650L
Dry weight.....	4785kg
Noise level @7m	76.8dBA
Dimensions L×W×H.....	4242×1614×2476mm
Standby Power	400kVA/320kW
Prime Power	375kVA/300kW

Voltage	380V	400V	415V		
Ampere	570A	541A	522A		
Genset Fuel Consumption					
Frequency/Load	25%	50%	75%	100%	110%
50Hz (L/h)	21.68	42.04	59.57	79.04	/

CONTACT US TODAY

1300 885 789 | paul@powergenaustralia.com.au
powergenaustralia.com.au

PowerGen
AUSTRALIA

AUTHORISED DEALER

Diesel Engine

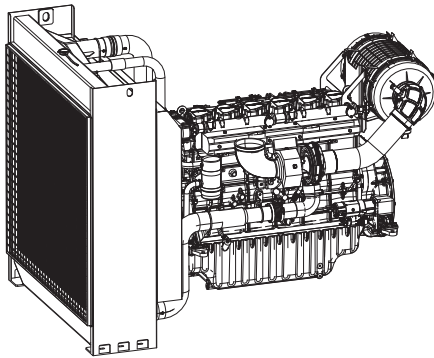

Engine Manufacturer/Brand.....	Baudouin
Engine Model.....	6M21G2D3/5
Dimensions L×W×H.....	2027 x 1105 x 1373mm
Dry Weigh (approx.)	1000kg
Number of Cylinders.....	6
Bore.....	127mm
Stroke	165mm
Displacement.....	12.54L
Compression Ratio	16
Type of Injection	High Pressure Common Rail
Intake System.....	Turbocharged and aftercooled
Intake Resistance	≤7.0kPa
Cooling System	Water cooled
Fan	Pusher
Battery Voltage	24V
Type of Fuel.....	BS2869 class A2 or BS EN590
Type of Oil	API CH4 15W/40
Oil Capacity	30L
Type of Coolant	Glycol Mixture
Coolant capacity	16.4L
Back Pressure	≤12kPa
Standby Power	385kW
Prime Power	350kW
Fuel Consumption(100%load).....	79.04L/h

Alternator

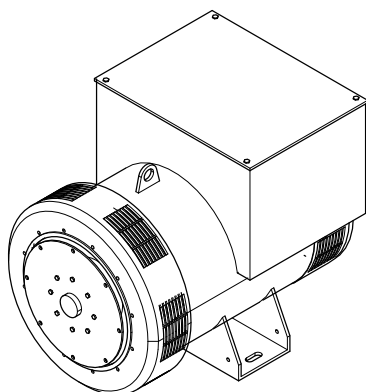

Alternator Manufacturer/Brand	Leroy Somer
Alternator Model	LSA47.2S4
Exciter.....	Brushless
Cooling Fan	Cast alloy aluminum
Windings.....	100% copper
Insulation Class	H
Winding Pitch	2/3
Terminals	6
Drip Proof	IP23
Altitude.....	≤1000m
Overspeed	2250rpm
Air Flow.....	1m³/s(50Hz), 1.2m³/s(60Hz)
Voltage Regulation	±0.5%
Total harmonic TGH / THC at no load < 4 % - on load < 4%	
Telephone Interference.....	THF<2%;TIF<50

PLC-7420 Control System

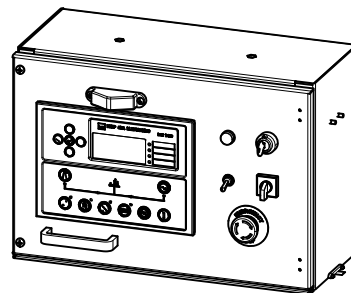

PLC-7420 is an advanced control module based on micro-processor, containing all necessary functions for protection of the genset and the breaker control. It can monitor the mains supply, and automatically start the engine when the mains is abnormal. Accurately measure various operational parameters and display all values and alarms information on the LCD. In addition, the control module can automatically shut down the engine and indicate the engine failure.

- Microprocessor control, with high stability and credibility
- Monitoring and measuring operational parameters of the mains supply and genset
- Indicating operation status, fault conditions, all parameters and alarms
- Multiple protections; multiple parameters display, like pressure, temp. etc.
- Manual, automatic and remote work mode selectable
- Real time clock for time and date display, overall runtime display, 250 log entries
- Overall power output display
- Integral speed/frequency detecting, telling status of start, rated operation, overspeed etc.
- Communication with PC via RS485 OR RS232 interface, using MODBUS protocol

CONTACT US TODAY

1300 885 789 | paul@powergenaustralia.com.au
powergenaustralia.com.au

PowerGen
— AUSTRALIA —

AUTHORISED DEALER

4 Overall Dimensions

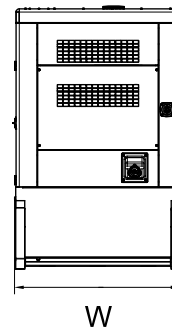
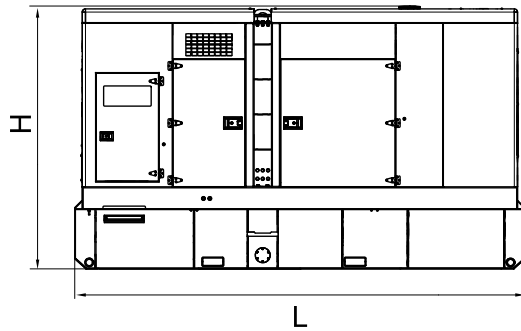
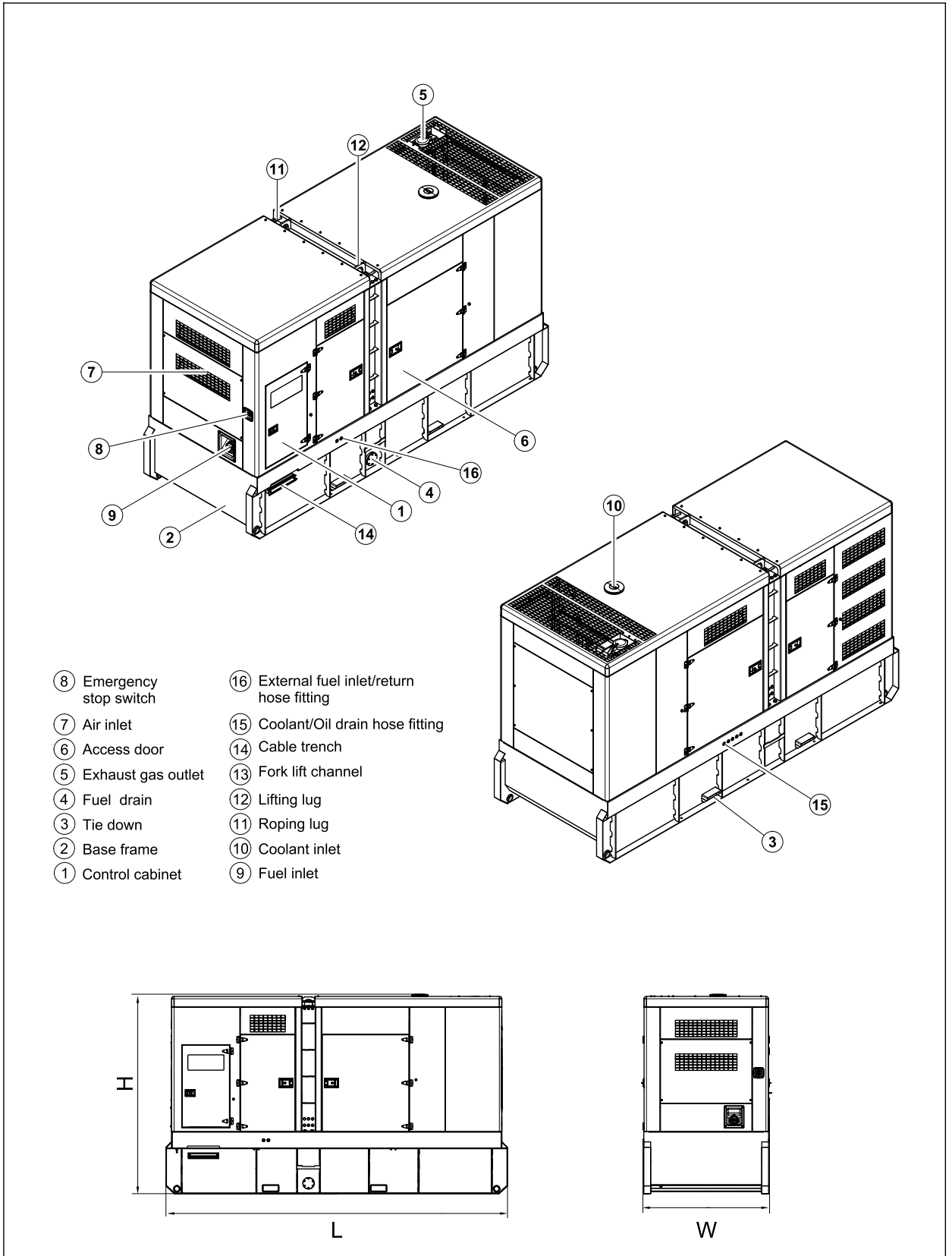

CONTACT US TODAY

1300 885 789 | paul@powergenaustralia.com.au
powergenaustralia.com.au

PowerGen
AUSTRALIA

AUTHORISED DEALER

5 Control System

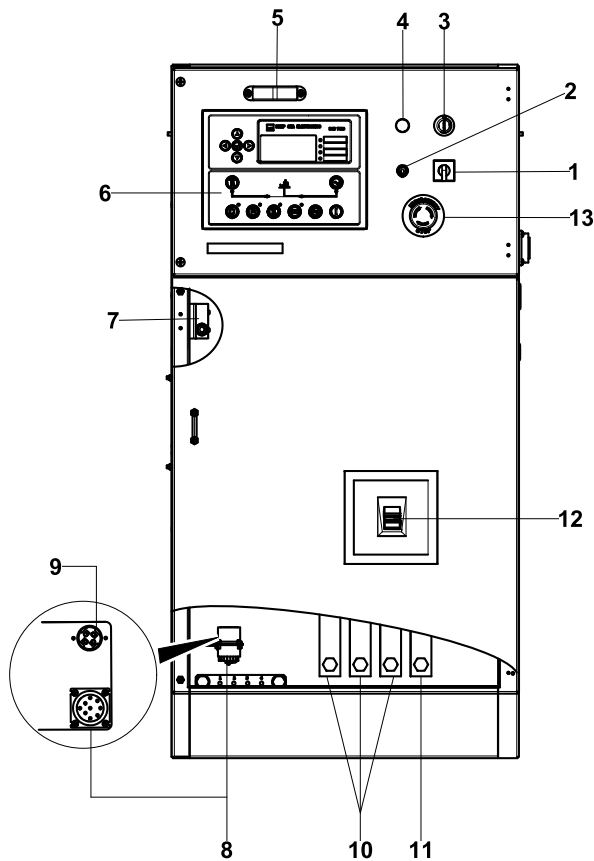

Control & Field wiring cabinet

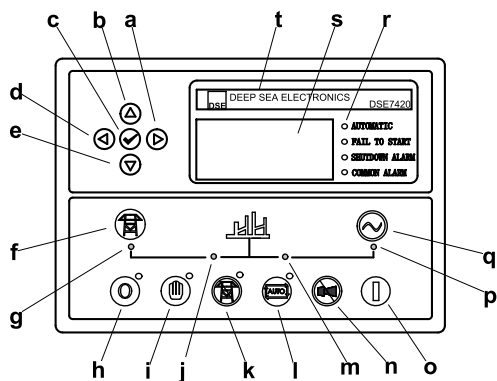

Control module

Ref.	Description
1	Control cabinet lamp switch
2	Mains input changeover switch
3	Charge indicator
4	Key switch
5	Control cabinet lamp
6	Control module
7	Limit switch
8	Mains input/ AMF communication connector
9	Mains input/ remote communication connector
10	Live wire terminals
11	Neutral wire terminal
12	Main circuit breaker
13	Emergency stop switch

a	Button (next page)
b	Button (increase value / previous item)
c	Button (accept)
d	Button (previous page)
e	Button (decrease value / next item)
f	Button (transfer the load to the mains supply, when in Manual mode only)
g	Mains supply available LED
h	Stop / Reset button
i	Manual button (Manual control mode)
j	Mains supply on load LED
k	Test button (Test mode)
l	Auto button (Auto mode)
m	Genset on load LED
n	Mute/Lamp test button
o	Start button (Manual)
p	Genset available LED
q	Button (transfer the load to the genset, when in Manual mode only)
r	Alarm LED (4 alarm items)
s	LCD display
t	Control module name

CONTACT US TODAY

1300 885 789 | paul@powergenaustralia.com.au
powergenaustralia.com.au

PowerGen
AUSTRALIA

AUTHORISED DEALER

1000034775-A2-E

10.2021

<http://www.powerlinkworld.com>

*Specification may change without prior notice. For more info.,
contact Power Link or your local distributors please.*

CONTACT US TODAY

1300 885 789 | paul@powergenaustralia.com.au
powergenaustralia.com.au

PowerGen
— AUSTRALIA —

AUTHORISED DEALER