

Generator set
Sound-proof type
B750SE3-AU

SPECIFICATIONS

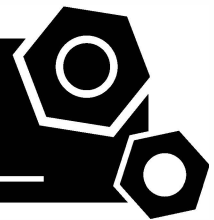

CONTACT US TODAY

1300 885 789 | paul@powergenaustralia.com.au
powergenaustralia.com.au

PowerGen
— AUSTRALIA —

AUTHORISED DEALER

Diesel Engine

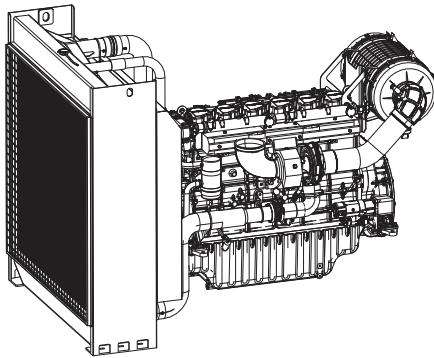

Engine Manufacturer/Brand.....	Baudouin
Engine Model.....	6M33G8D3/5
Dimensions L×W×H.....	2798x1680x1954mm
Dry Weigh (approx.)	2472kg
Number of Cylinders.....	6
Bore.....	150mm
Stroke	185mm
Displacement.....	19.6L
Compression Ratio	15.0
Type of Injection	High Pressure Common Rail
Intake System.....	Turbocharged and aftercooled
Intake Resistance	≤6.5kPa
Cooling System	Water cooled
Fan	Pusher
Battery Voltage	24V
Type of Fuel.....	BS2869 class A2 or BS EN590
Type of Oil	API CH4 15W/40
Oil Capacity61L
Type of Coolant	Glycol Mixture
Coolant capacity	159L
Back Pressure	≤7.5kPa
Standby Power725kW
Prime Power675kW
Fuel Consumption(100%load).....	158L/h

Alternator

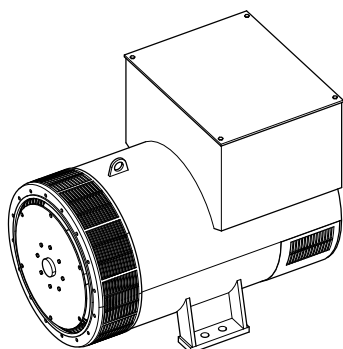

Alternator Manufacturer/Brand	Leroy Somer
Alternator Model	LSA49.3M65
Exciter.....	Brushless
Cooling Fan	Cast alloy aluminum
Windings.....	100% copper
Insulation Class	H
Winding Pitch	2/3
Terminals	6
Drip Proof	IP23
Altitude.....	≤1000m
Overspeed	2250rpm
Air Flow.....	1m³/s(50Hz),1.2m³/s(60Hz)
Voltage Regulation	±0.5%
Total harmonic TGH / THC at no load < 4 % - on load < 4%	
Telephone Interference.....	THF<2%;TIF<50

PLC-500 Control System

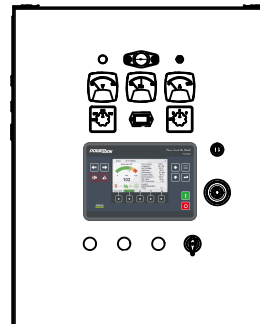

PLC-500 is a microprocessor based control unit containing all necessary functions for protection of the genset and the breaker control. Furthermore, it contains all necessary three-phase measuring circuits and presents all values and alarms on the LCD display. The module has the function of load sharing which enables the module to share the active load (kW) equally when operating in parallel with other gensets. The load sharing is performed so each genset takes a portion of the load that is calculated in percent according to the nominal power.

- Microprocessor control, with high stability and credibility
- Monitoring and measuring operational parameters of the genset
- Indicating operation status, fault conditions, all parameters and alarms
- Multiple protections; multiple parameters display, like pressure, temp. etc.
- Manual, automatic and remote work mode selectable
- RS232 & RS485 can be used at the same time
- Real time clock for time and date display, overall runtime display, 250 log entries

CONTACT US TODAY

1300 885 789 | paul@powergenaustralia.com.au
powergenaustralia.com.au

PowerGen
AUSTRALIA

AUTHORISED DEALER

4 Overall Dimensions

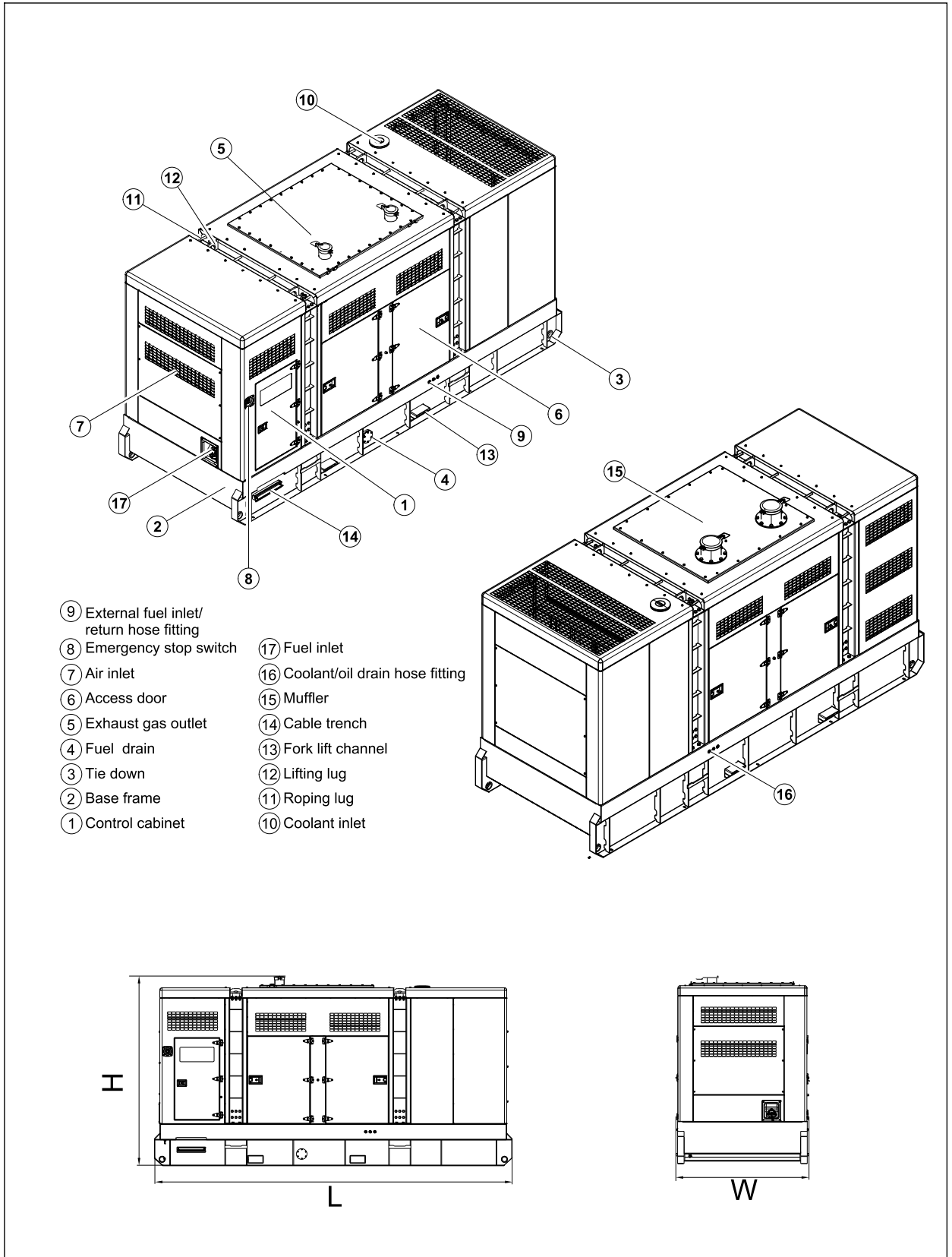

CONTACT US TODAY

1300 885 789 | paul@powergenaustralia.com.au
powergenaustralia.com.au

PowerGen
AUSTRALIA

AUTHORISED DEALER

5 Control System

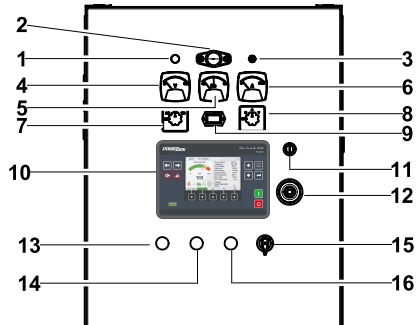

Control cabinet

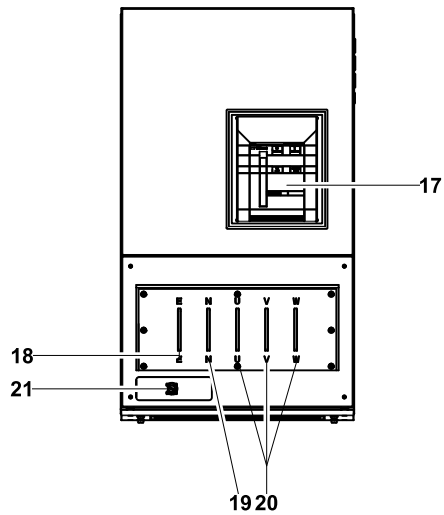

Field wiring cabinet

Ref.	Description
1	Charge indicator
2	Control cabinet lamp
3	Control cabinet lamp switch
4	Voltage meter
5	Frequency meter
6	Current meter
7	Changerover switch-Voltage
8	Changerover switch-Current
9	Time counter
10	Control module
11	Key switch
12	Emergency stop switch
13	GCB closed indicator
14	GCB opened indicator
15	Control power switch
16	Alarm reset button
17	Main circuit breaker
18	Ground wire terminal
19	Neutral wire terminal
20	Live wire terminals
21	Paralleling connector with the mains

CONTACT US TODAY

1300 885 789 | paul@powergenaustralia.com.au
powergenaustralia.com.au

PowerGen
— AUSTRALIA —

AUTHORISED DEALER

A2-E
12.2021

<http://www.powerlinkworld.com>

*Specification may change without prior notice. For more info.,
contact Power Link or your local distributor.*

CONTACT US TODAY

1300 885 789 | paul@powergenaustralia.com.au
powergenaustralia.com.au

PowerGen
— AUSTRALIA —

AUTHORISED DEALER

© 2021 POWERLINK